

magourban



**made for  
urban living...**

Magourban pone a tu disposición todo el conocimiento, experiencia e infraestructura industrial para fabricar cualquier elemento de mobiliario urbano o arquitectónico.

Magourban posa a la teva disposició tot el coneixement, experiència i infraestructura industrial per fabricar qualsevol element de mobiliari urbà o arquitectònic.

*Magourban places all its knowledge, experience and infrastructures at your disposal for manufacturing any element for urban or architectural furniture.*

*Magourban met à votre disposition toute la connaissance, l'expérience et l'infrastructure industrielle pour fabriquer tout type d'élément de mobilier urbain ou architectural.*

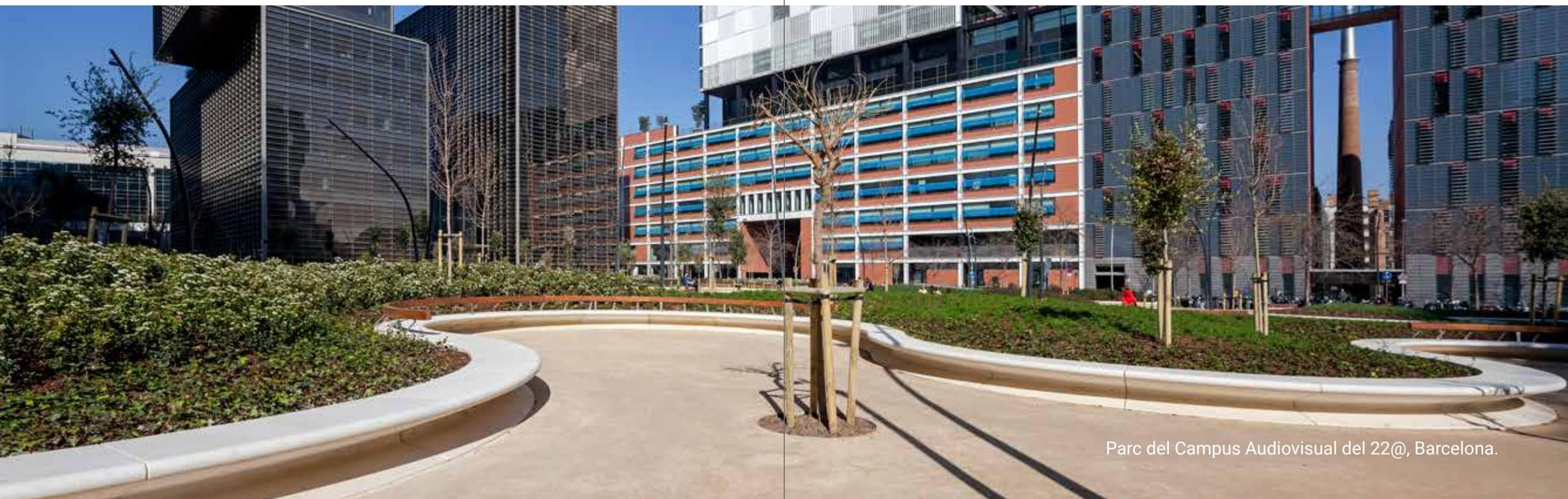

Parc del Campus Audiovisual del 22@, Barcelona.



Parc del Campus Audiovisual del 22@, Barcelona.



**custom-made...**

Paseo del Espigón Norte, Puerto de Gandía.

# “Manufacturing your designs”

© Bow Design by Cristina Lloret | Xavier Vilagrán

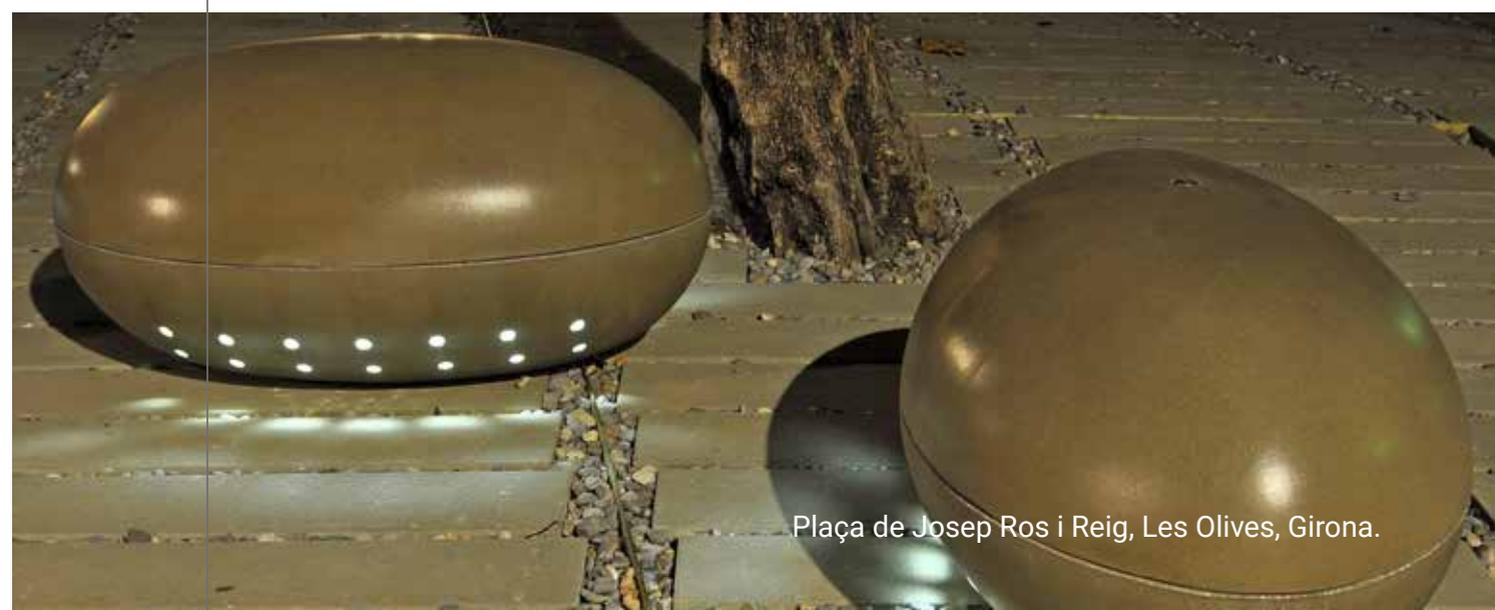

Plaça de Josep Ros i Reig, Les Olives, Girona.

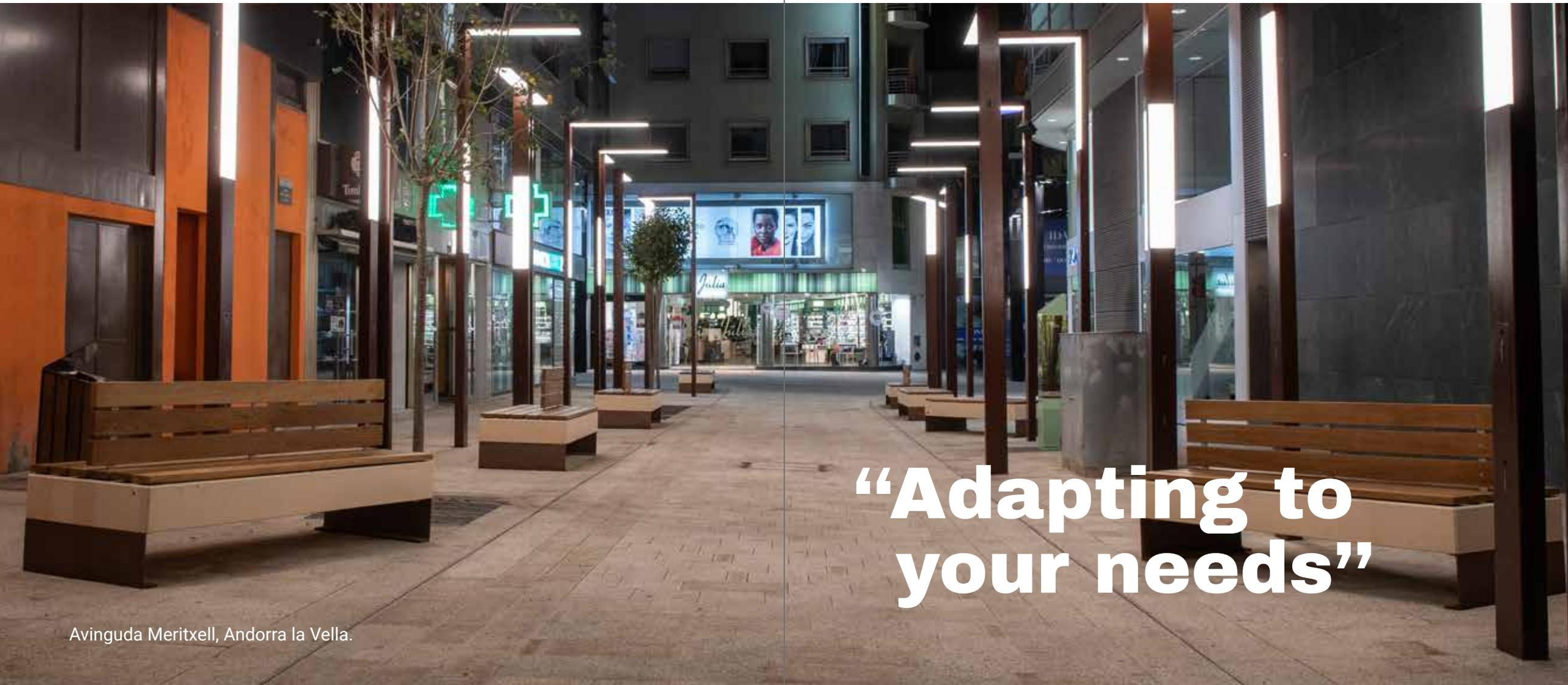

**“Adapting to  
your needs”**



# Sun-Set, smart city line

by In-Tenta

Un nuevo concepto de espacio público, inteligente y saludable, concebido como una extensión de nuestros hogares, donde disfrutar al aire libre sin renunciar a las nuevas necesidades surgidas de las tecnologías móviles. Espacios que ofrecen protección frente al contagio y cuidan de las personas y de nuestro entorno. Producción responsable que está presente en todas las fases del proceso productivo, diseño, fabricación, transporte, montaje, vida útil, reciclaje...

*A new intelligent and healthy concept for public spaces, conceived as an extension of our homes, where we can enjoy outdoors without renouncing to the new necessities emerged from mobile technologies. Spaces which offer protection against contagion and take care of our people and environment. Responsible production present in all phases of the productive processes, designing, manufacturing, transporting, assembling, life of usage, recycling...*

Un nou concepte d'espai públic, intel·ligent i saludable, concebut com una extensió de les nostres llars, on gaudir a l'aire lliure sense renunciar a les noves necessitats sorgides de les tecnologies mòbils. Espais que ofereixen protecció davant el contagi i tenen cura de les persones i del nostre entorn. Producció responsable que està present en totes les fases del procés productiu, disseny, fabricació, transport, muntatge, vida útil, reciclatge...

*Un nouveau concept d'espace public, intelligent et sain, conçu comme une extension de nos foyers, où nous profitons de l'aire libre sans renoncer aux besoins surgit de la technologie mobiles. Des espaces qui offrent protection contre la contagion et prend soin des personnes et de notre entourage. Production responsable présente dans toutes les phases du processus productif, design, fabrication, transport, montage, vie utile, recyclage... etc*



**“Conscious urban design for smart healthy cities”**



▲ **Sun-Set picnic**  
Ver p. 203 | See p. 203

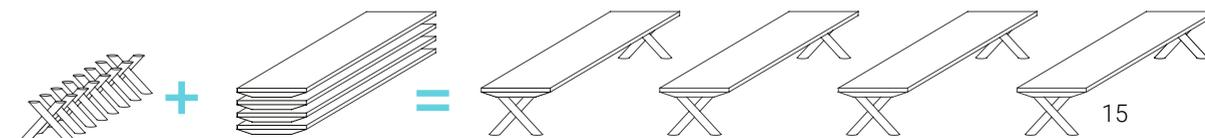
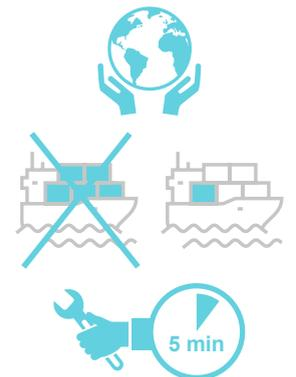



**Sun-Set B 300**

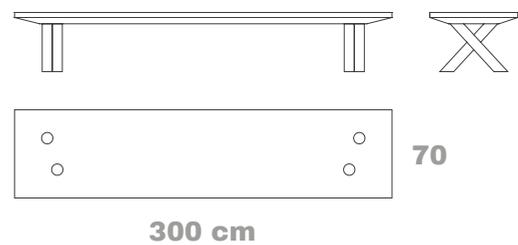

**Sun-Set B 220**

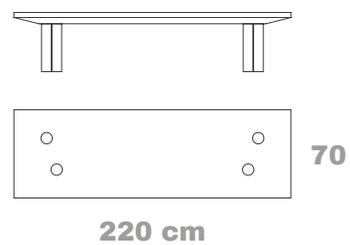

 **Iluminación LED opcional**  
Optional LED lighting





**Sun-Set recycling**

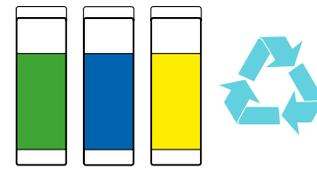
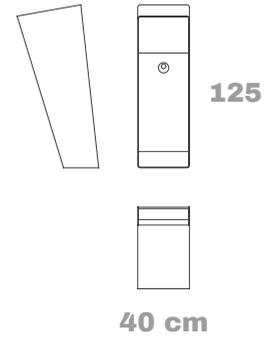

**Sun-Set health**

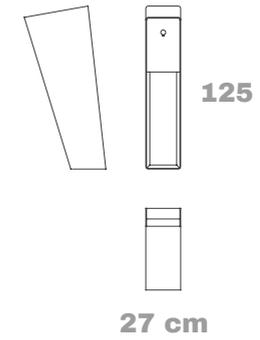

**Sun-Set cycling**

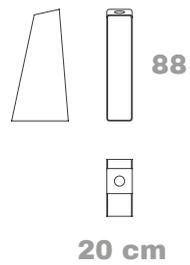

# Petra Collection



**bancos**  
bancs  
**benches**  
bancs



**Abellir**  
57



**Andra**  
118



**Areca**  
55



**Dish**  
53



**Dove**  
110



**Dynamic**  
130



**Flip-it**  
52



**Bali**  
57



**Barrera**  
106



**Bécquer**  
126



**Beta**  
108



**Gandhi**  
114



**Gant**  
137



**Gaviotas**  
68



**Geométrico**  
101



**Blink**  
30



**Bloop**  
90



**Bus**  
138



**Campus**  
38



**Grap**  
58



**Hache**  
70



**Hat**  
136



**Luce**  
36



**Coma**  
37



**Confeti**  
40



**Crusöe**  
66



**Cuc**  
46



**Manyanet**  
62



**MDT**  
120



**Mesull**  
95



**Modulblock**  
125

**bancos**  
bancs  
**benches**  
bancs



**Nú**  
116



**Olive**  
74



**Ona**  
72



**Sore**  
117



**Targa**  
78



**Tetris**  
80



**Tippy**  
86



**Origami**  
50



**Pausa**  
75



**Pilosilla**  
48



**Ponte**  
128



**Tube**  
96



**Ubloc**  
49



**Unió**  
112



**Unit**  
54



**Practic**  
94



**Public**  
32



**Ripple**  
42



**Russes**  
76



**Vinyes**  
98



**Waves**  
100



**Zen**  
102



**Sassi**  
84



**Sedàs**  
56



**Sit-up**  
64



**Sol**  
124

**jardineras**  
**jardineres**  
**planters**  
**jardinières**



**Bol**  
166



**Cantorodado**  
150



**Circular**  
161



**Ese**  
162



**Espace**  
168



**Fuat**  
152



**Granpot**  
154



**Hat**  
164



**Hex**  
153



**Koniq**  
148



**Lis**  
163



**Malva**  
156



**Tanit**  
146



**Uve**  
160



**Zaphir**  
167



**recogida residuos**  
**recollida residus**  
**waste collection**  
**collecte de déchets**  
170



**límites**  
**límits**  
**bollards**  
**limites**  
182



**pícnic**  
**pícnic**  
**picnic**  
**pique-nique**  
200



**pavimentos**  
**paviments**  
**pavements**  
**revêtements**  
212



**miscelánea**  
**miscelània**  
**miscellaneous**  
**divers**  
232



**accesorios**  
**accessoris**  
**accessories**  
**accessoires**  
240



**bancos**  
**bancs**  
***benches***  
***bancs***





# Blink

by Ton Riera



Asientos que dotan de ligereza y amplitud a los espacios urbanos. Un mobiliario que respira y brilla con luz propia.

Seients dissenyats per donar lleugeresa i amplitud als espais urbans. Un mobiliari que respira i brilla amb llum pròpia.

*Seats that give urban spaces a light, spacious feel. Furniture that breathes and shines with a light of its own.*

*Des sièges qui apportent légèreté et amplitude aux espaces urbains. Mobilier qui respire et brille par lui-même.*

## Blink C

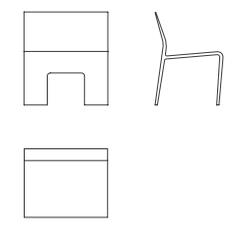

## Blink B

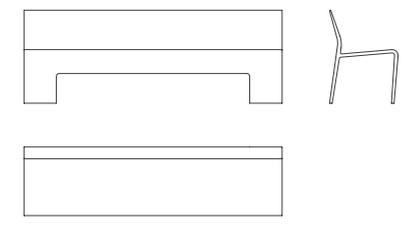

200 cm



# Public

by los diez

Public



Public 3P

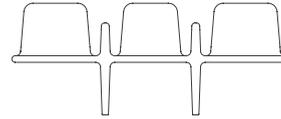

210 cm



## Pensar en el mobiliario urbano es pensar en la gente.

Cuando se construye o reforma cualquier calle, plaza, parque, etc, los ciudadanos se adaptan a lo impuesto por los profesionales del diseño y las instituciones que lo llevan a cabo. Previamente dichos "interventores" de los proyectos nos hemos preocupado e interesado por las necesidades y hábitos de las personas en relación al uso del espacio público ya que es en este lugar donde se establecen las relaciones con el mundo exterior, fuera del trabajo y del hogar.

Ofreciendo una amplia gama de posibilidades en cuanto a la orientación y las relaciones proxémicas, Public se ha convertido en el claro ejemplo que refleja el diseño inclusivo, para todos.



## To think about urban furniture is to think about people.

When building or renovating any street, square, park, etc., citizens adapt to what is imposed by design professionals and the institutions that carry it out. However, we have been concerned and interested in the needs and habits of people in relation to the use of public space, since it is in this place where relations are established with the outside world, outside of work and home.

Offering a wide range of possibilities in terms of orientation and proxemic relationships, Public has become the clear example that reflects inclusive design, for all.

## Dos conceptos en un mismo diseño.

Extender y deslizar son los dos conceptos que se han fusionado a la hora de diseñar Public, un banco de hormigón UHPC formado por dos patas o brazos centrales de los cuales se sostienen dos asientos laterales y uno central, facilitando así el uso de este último en el momento crítico de tomar asiento o levantarse, sobre todo a los sectores sensibles de la población como son los ancianos, discapacitados, embarazadas o personas con sobrepeso.

Al mismo tiempo, el hecho que los asientos laterales no estén limitados por su parte exterior permite aumentar su ancho proporcionando una mayor amplitud respecto a la plaza localizada entre apoyabrazos.

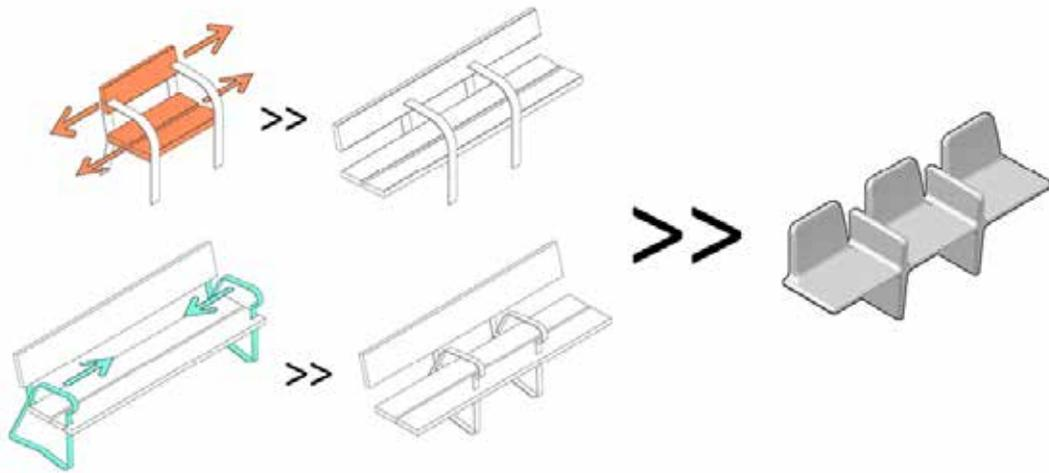

## Two concepts in one design.

Extending and sliding are the two concepts that have merged at the time of designing Public, a UHPC concrete bench formed by two legs or central arms from which two lateral seats and one central seat are supported, thus facilitating its use by the latter at the critical moment of taking a seat or getting up, above all to the sensible sectors of the population such as the elderly, the disabled, pregnant women or overweight people.

At the same time, the fact that the side seats are not limited on the outside makes it possible to enlarge their width by providing a greater width with the seating position located between the armrests.

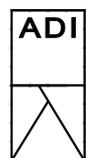

ADI - FAD  
2016



Premio  
Diseño para todas las  
personas / Fundación ONCE



# Luce

by Jesús Alfaro, Ana Hurtado

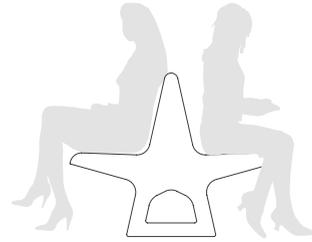

Estrellas modulares que forman un banco a dos caras y que se adaptan con facilidad a diferentes entornos.

Estels modulars que formen un banc a dues cares que s'adapta amb facilitat a diferents entorns.

*Modular stars that form a two-sided bench, easily adaptable to different environments.*

*Étoiles modulaires formant un banc double face qui s'adapte facilement à différents environnements.*

**Luce**

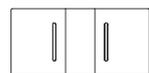
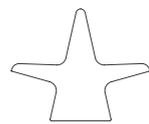

**Luce R**

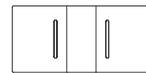
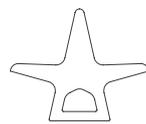

**Luce 19**



**Luce 27**

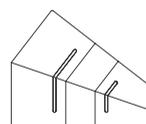

Un asiento que incita a realizar una pausa en el camino.

Un seient que convida a fer una pausa en el camí.

*A seat that invites you to stop and take a break along the way.*

*Un siège qui invite à faire une pause sur le chemin.*

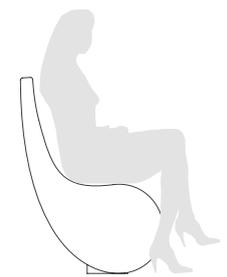

# Coma

by Joan Cinca

# Campus



Campus cóncavo

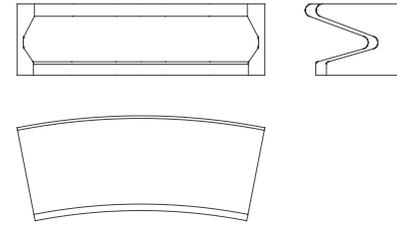

191 cm

Campus convexo

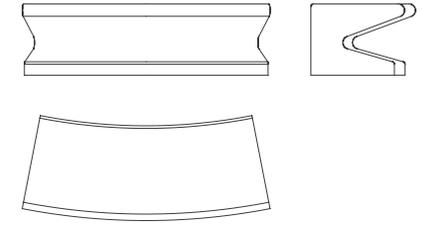

191 cm



 Iluminación LED opcional  
Optional LED lighting

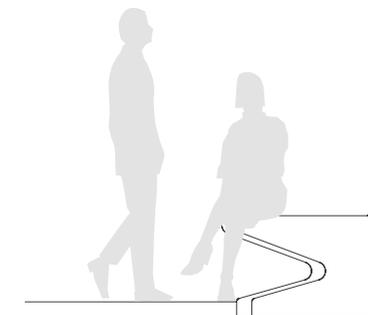



# Confeti



Salpica de diversión cualquier espacio, haz de tu ciudad una fiesta.

Esquitxa de diversió qualsevol espai, fes de la teva ciutat una festa.

*Splashes of fun anywhere; turn your city into a party.*

*Du divertissement parsemé dans tout type d'espace pour que votre ville soit en fête.*



colores | colors

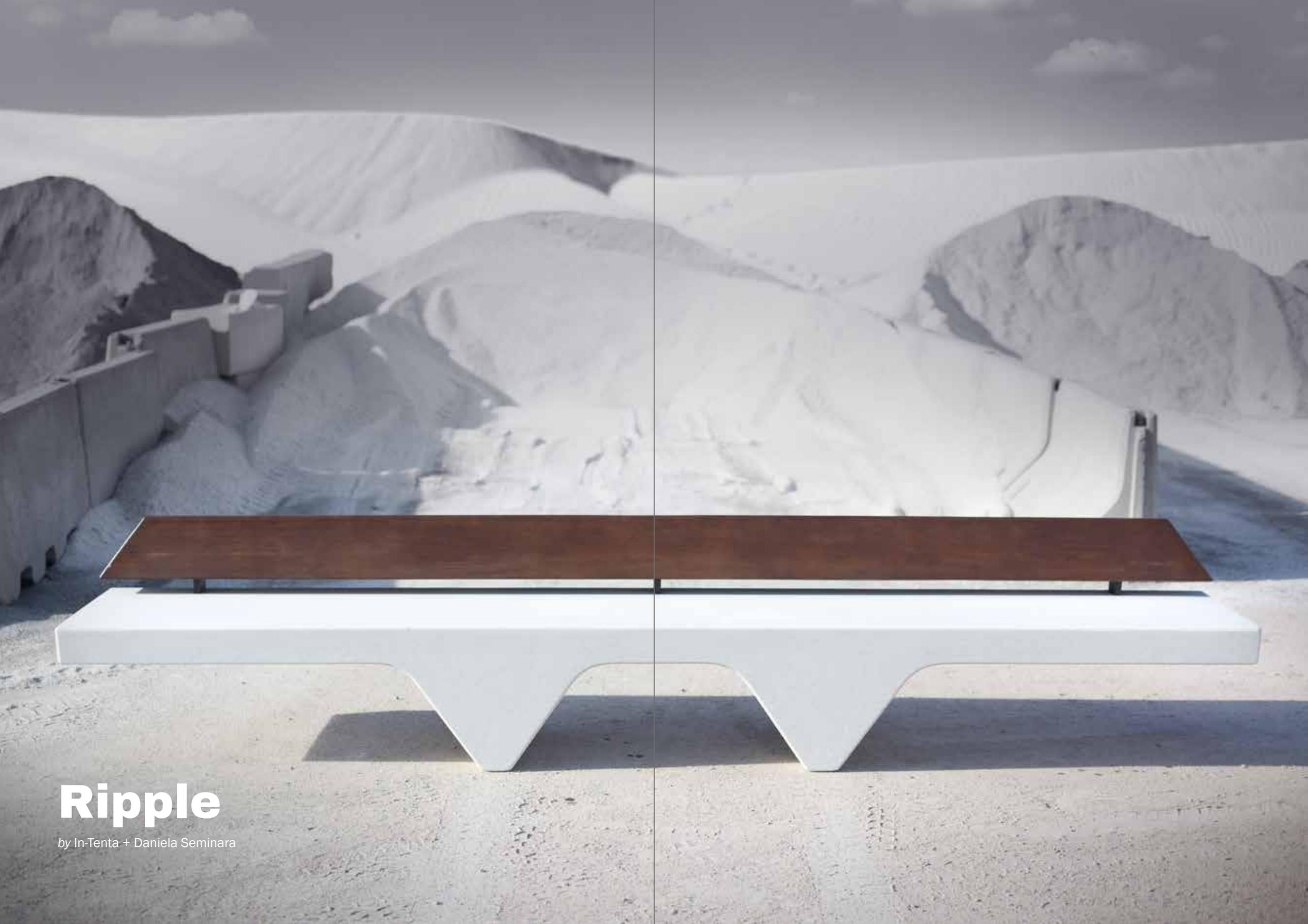

# Ripple

by In-Tenta + Daniela Seminara



Banco de gran formato inspirado en los 'Ripples', pequeñas dunas formadas por granos de fina arena transportados por el viento del desierto.

Banc de gran format inspirat en els 'Ripples', petites dunes formades per grans de fina sorra transportats pel vent del desert.

*Large-format bench inspired by 'Ripples', small dunes formed by grains of fine sand transported by the desert wind.*

*Banc de grande taille inspiré par les « Ripples », de petites dunes constituées de fins grains de sable transportés par le vent du désert.*

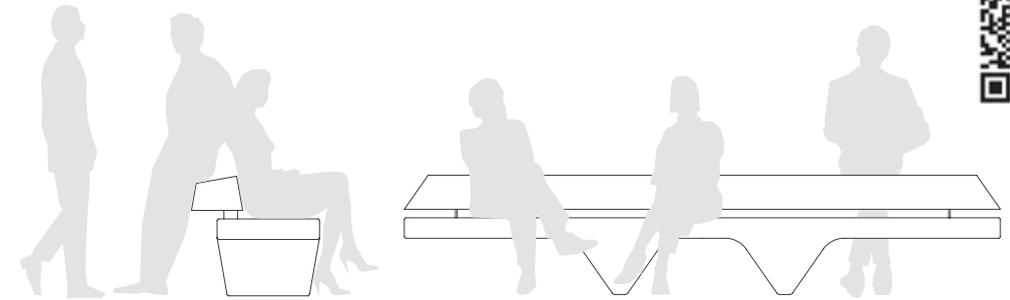

**Ripple BR 240**

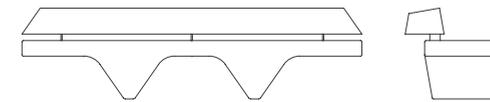

**240 cm**

**Ripple B 240**

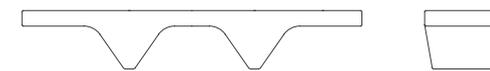

**240 cm**

**Ripple BR 350**

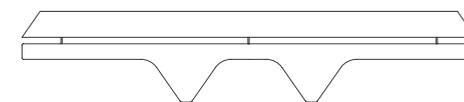

**350 cm**

**Ripple B 350**

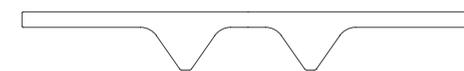

**350 cm**

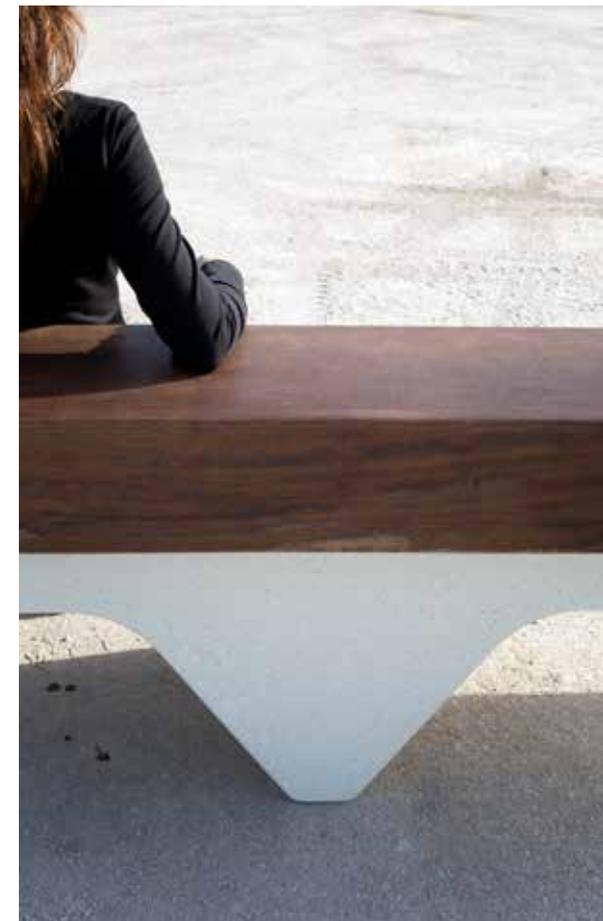





# Cuc

by Foreign Office Architects  
Farshid Moussavi, Alejandro Zaera Polo  
special thanks to Kenichi Matsuzawa



ADI - FAD  
2005



Articula el espacio para  
compartirlo individualmente.

Articula l'espai per compartir-lo  
individualment.

*Articulate the space to share it  
individually.*

*Articule l'espace pour le partager  
individuellement.*

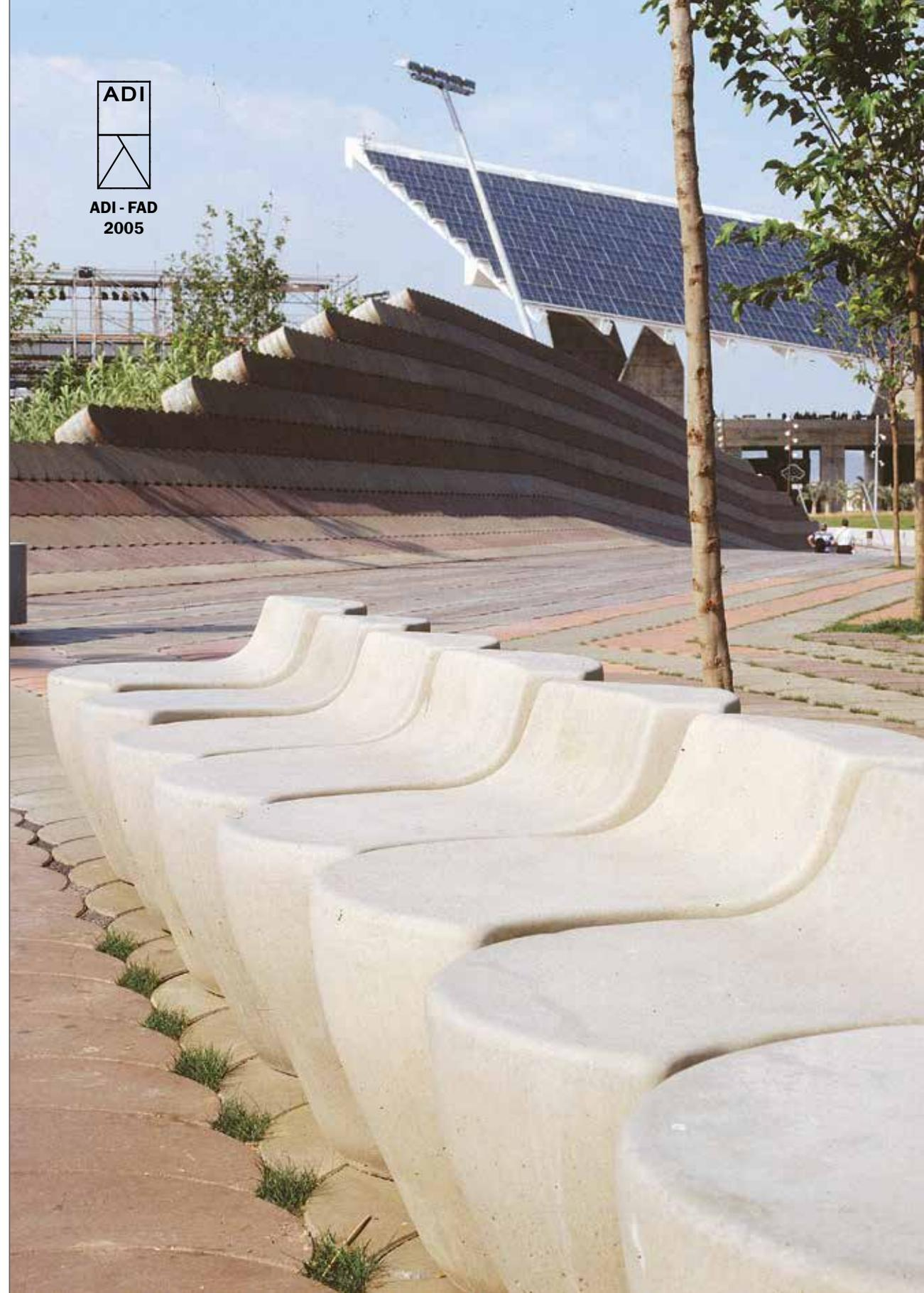
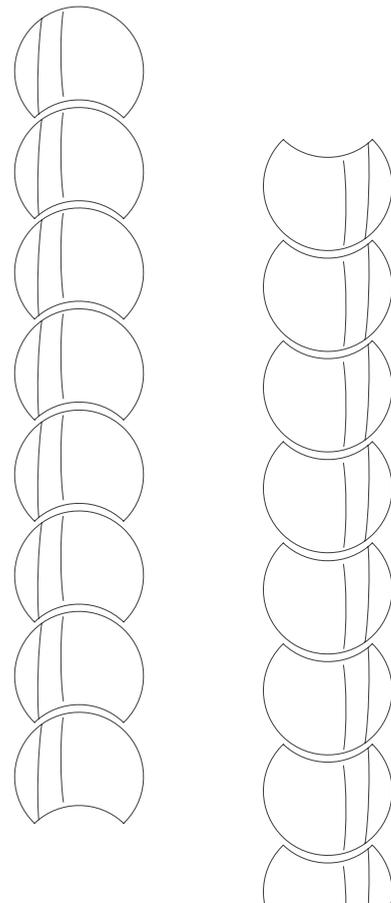

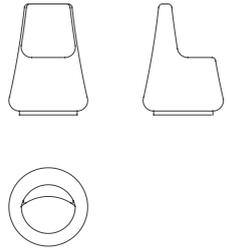

# Pilosilla

by SUMA Arquitectes



Mobiliario sólido y contundente que elimina cualquier indecisión.

Mobiliari sòlid i contundent que no deixa espai a la indecisió.

*Solid and blunt urban furniture that rules out all indecision.*

*Mobilier solide et percutant qui ne laisse pas le moindre doute.*

# Ubloc

by Xavi Ferrús

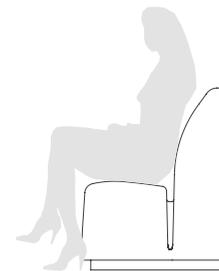

# Origami

by Ernest Perera



Origami es el arte nipón de doblar papel y ahora es también la técnica de doblar el hormigón.

*Origami is the Japanese art of folding paper, and now it's also the technique of folding concrete.*

Origami és l'art japonès de doblegar paper i ara és també la tècnica de doblegar el formigó.

*L'origami est l'art japonais du pliage du papier, une technique désormais applicable au béton.*



**Origami BR**

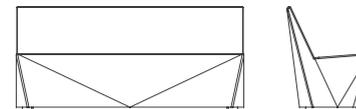

180 cm

**Origami J | 250 L**

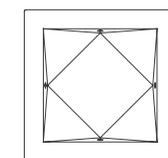

120

120 cm

**Origami B**



180 cm

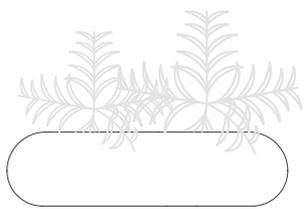

# Flip-it

by La Noche de la Iguana  
Kiko Solsona

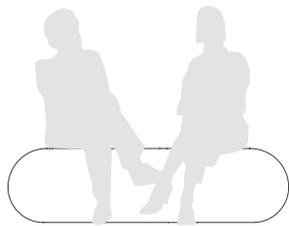

Flip-it J | 350 L



Flip-it B

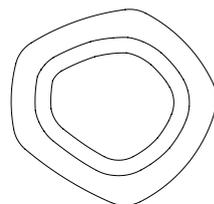

170 cm

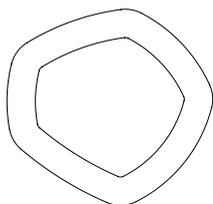

170 cm



Jardinera de gran formato para crear volúmenes verdes.

Jardinera de gran format per crear volums verds.

*Large-format planter to create green volumes.*

*Jardinière de grande taille pour créer des volumes verts.*

# Dish

by Guido Marsille

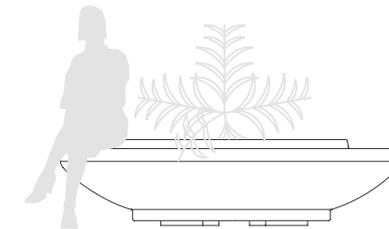

Ø 190 cm  
335 L





# Areca

Areca

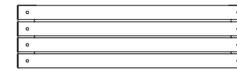

180 cm

Areca R

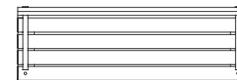

# Unit

by Ernest Perera

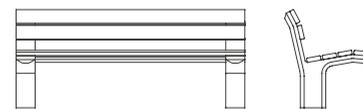

180 cm





# Sedàs

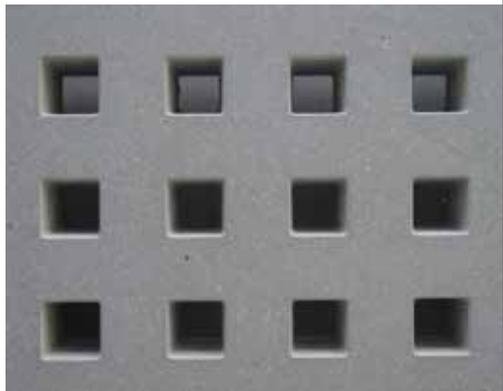
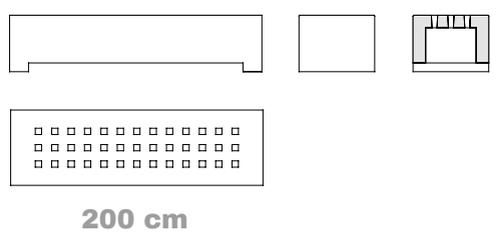

# Abellir

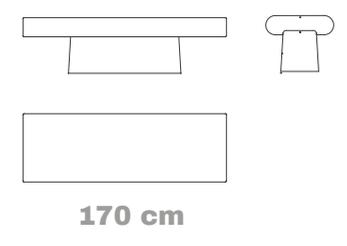

# Bali

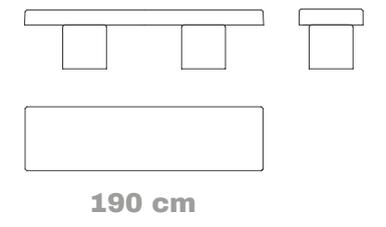

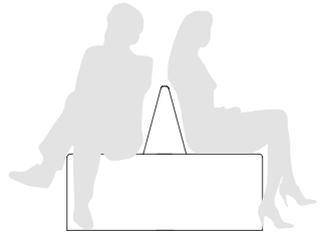

# Grap



Formas orgánicas de la naturaleza que colonizan la ciudad y rompen con la rigidez de la trama urbana.

*Organic shapes inspired by nature that colonise the city and break with the rigidity of the urban pattern.*

Formes orgàniques de la natura que colonitzen la ciutat i trenquen amb la rigidesa de la trama urbana.

*Formes organiques de la nature qui colonisent la ville et rompent avec la rigidité du tissu urbain.*

**Grap G**

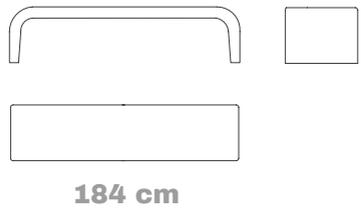

**Grap P**

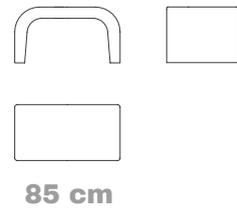

**Grap C**

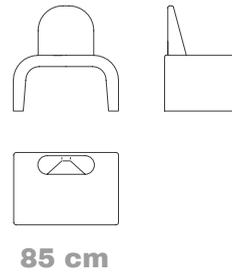

**Grap R**

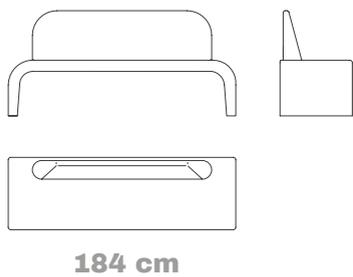

**Grap duo**

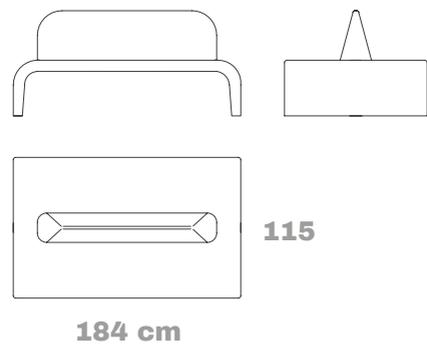

● Apoyabrazos opcional  
*Optional Arm-rest*





Grap duo

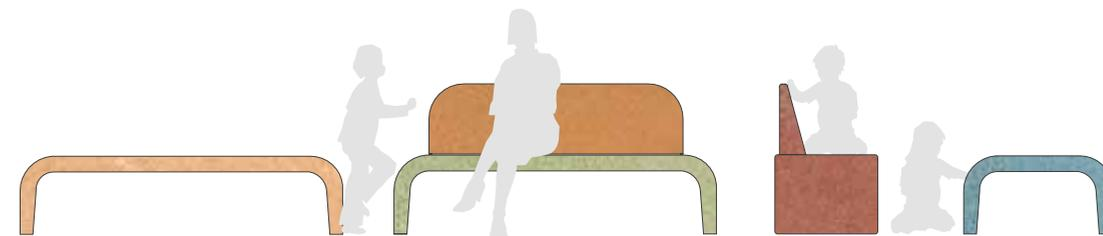

colores | colors





**Manyanet 200**



**Manyanet 300**



**Manyanet**

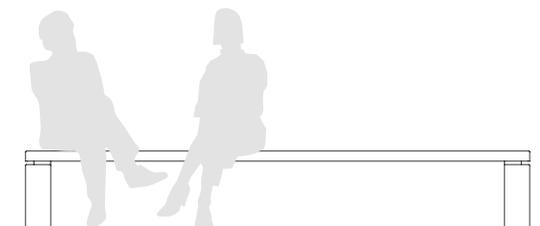

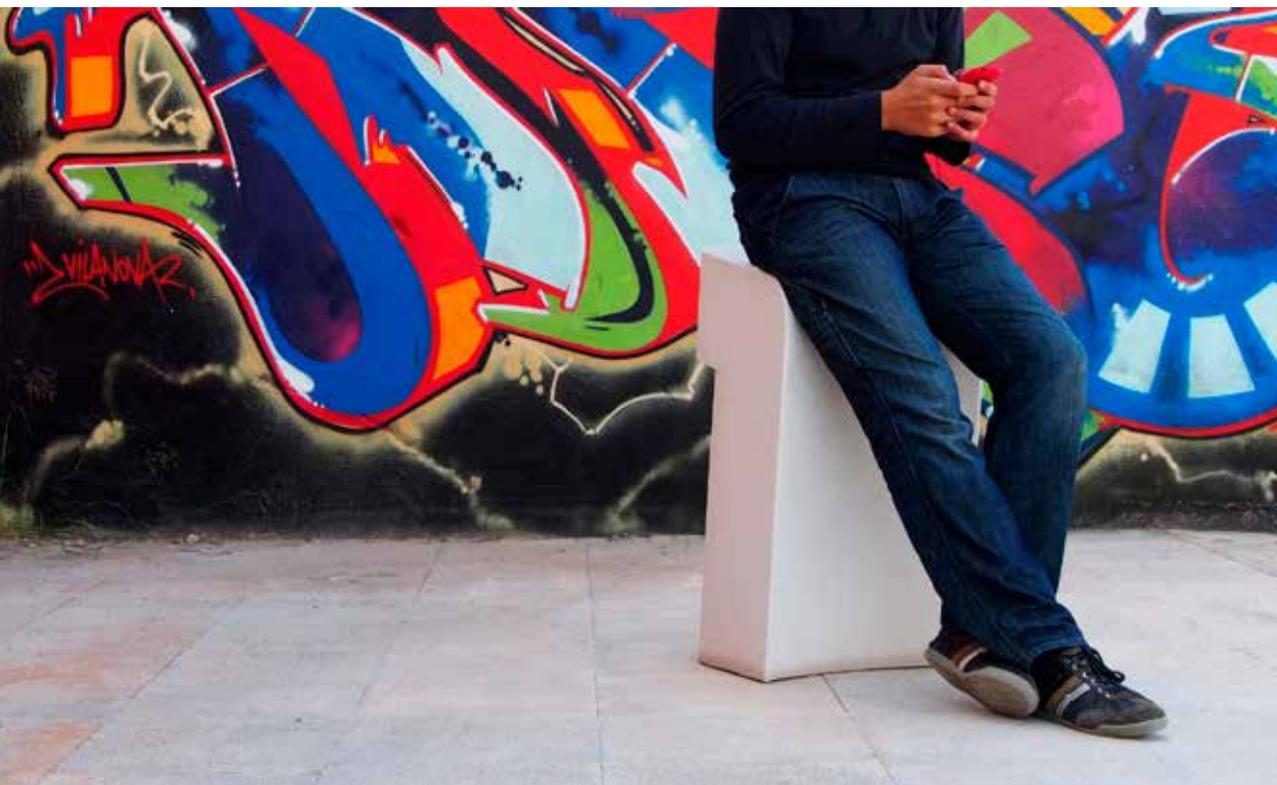

DELTA AWARDS'14

Selected

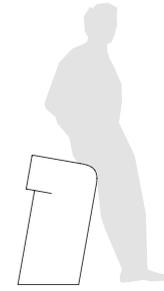

# Sit-up

by Alòs Ideas

A menudo la sencillez y la multifuncionalidad pueden ir de la mano. Elemento con el que podemos decorar, limitar, iluminar y hacer una pausa.

*Simplicity and multifunctionality can often go hand in hand. This element can be used to decorate, illuminate and for a short break.*

Sovint la senzillesa i la multifuncionalitat poden anar juntes. Element amb el qual podem decorar, limitar, il·luminar i fer una pausa.

*La simplicité et la polyvalence peuvent souvent aller de pair. Avec cet élément, il est possible de décorer, de délimiter, d'éclairer et de faire une pause.*

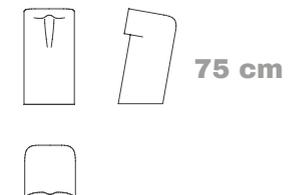

Iluminación LED opcional  
Optional LED lighting

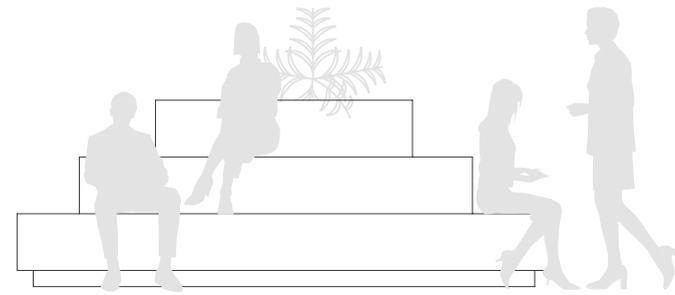

# Crusöe

by Roger Albero

Una isla en medio de la urbe.  
Ocupa espacios en diferentes alturas.

Una illa enmig de la urbs. Ocupa espais en diferents alçades.

*An island in the middle of the city.  
Filling spaces at different levels.*

*Une île en plein cœur de la ville.  
Occupe les espaces à différentes hauteurs.*

**Crusöe C | 248 L**

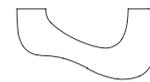

**Crusöe B | 338 L**

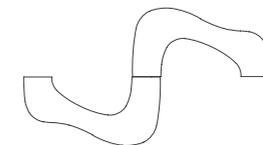
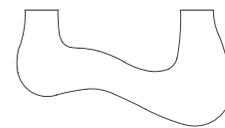

**Crusöe A | 709 L**

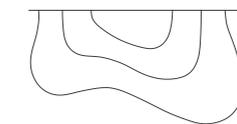
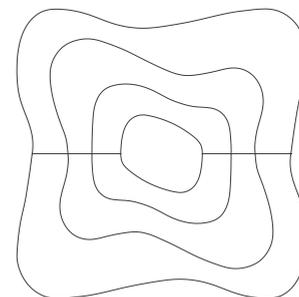
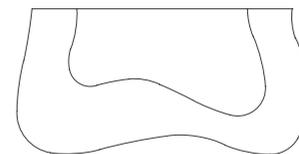

330 cm



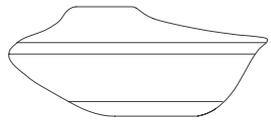
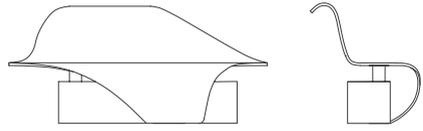

200 cm

Nuestro banco más onírico, de naturaleza tranquila y silenciosa que sugiere a una gaviota batiendo sus alas hacia la libertad.

*Our dreamiest bench, peaceful and silent, looking like a seagull flapping its wings towards freedom.*

# Gaviotas

by Ewald Winkelbauer

El nostre banc més oníric, de naturalesa tranquil·la i silenciosa que suggereix a una gavina batent les seves ales cap a la llibertat.

*Notre banc le plus onirique, qui rappelle une mouette battant des ailes vers la liberté.*

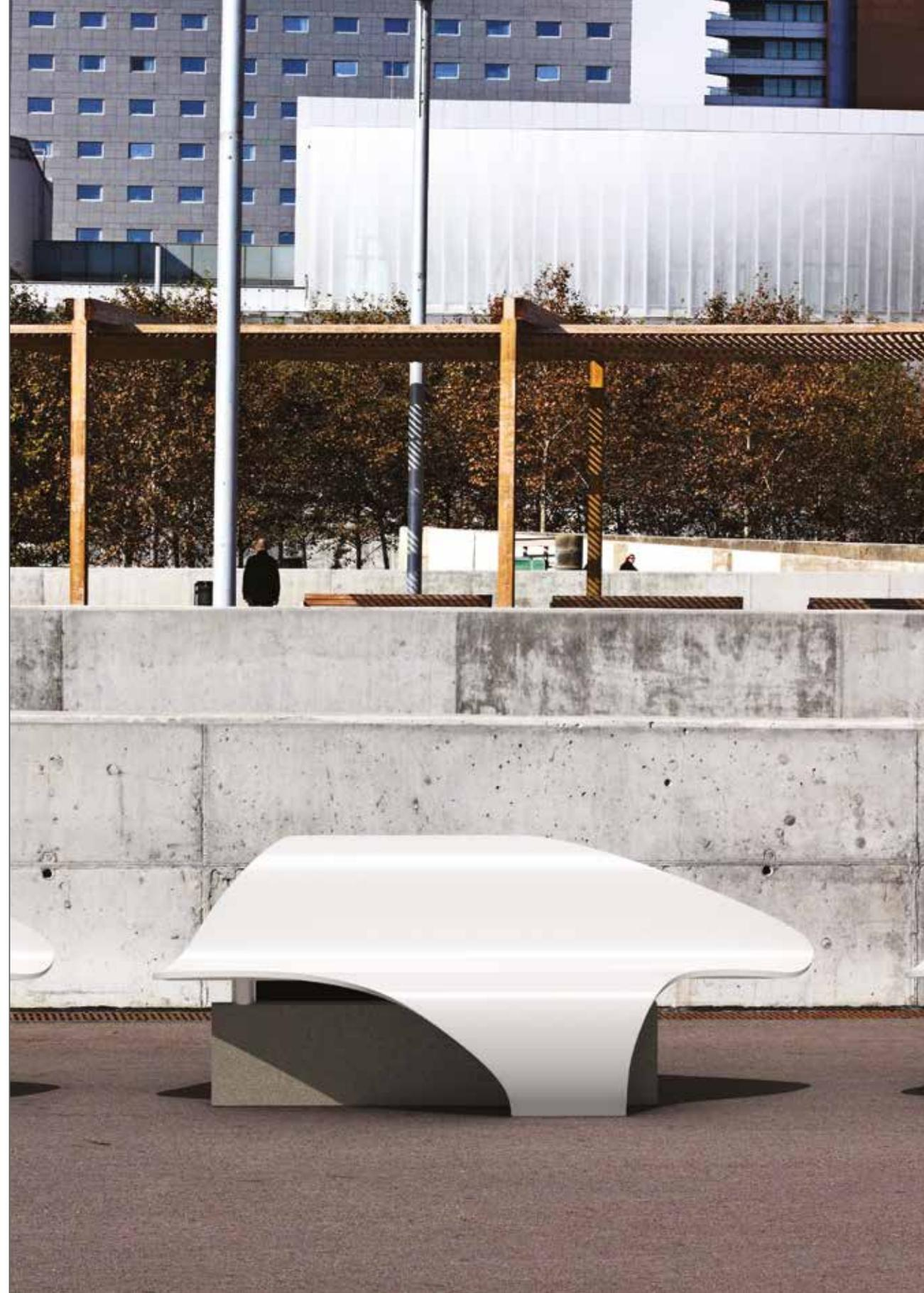

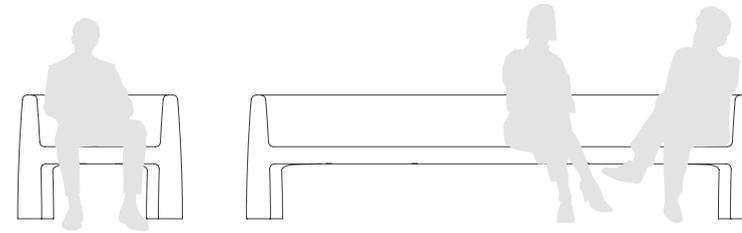

# Hache

by Ernest Perera

Asientos que insinúan los antiguos 'tú y yo', ideales para crear espacios acogedores.

*Seats with a nod to the old-fashioned loveseat - perfect for creating welcoming spaces.*

Seients que insinuen els antics 'tu i jo', ideals per crear espais acollidors.

*Sièges qui évoquent les « vis-à-vis » d'antan, idéals pour créer des espaces accueillants.*



**Hache CN**

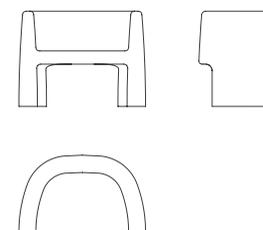

**Hache BN**

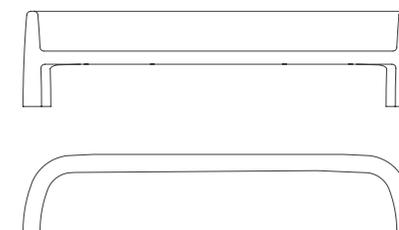

300 cm



# Ona

by Oriol Pardo

Elementos curvilíneos y sugerentes que suavizan los espacios.

*Curvilinear and suggestive elements that soften spaces.*

Elements curvilinis i suggerents que suavitzen els espais.

*Éléments curvilignes et suggestifs qui adoucissent les espaces.*

**Ona cóncavo**

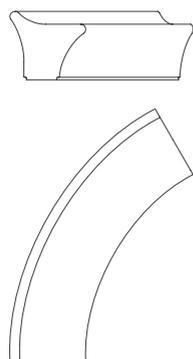

**Ona convexo**

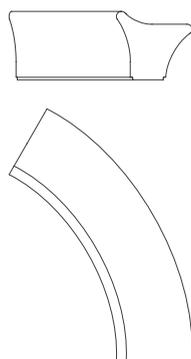

**Ona recto**



**Ona C 90**

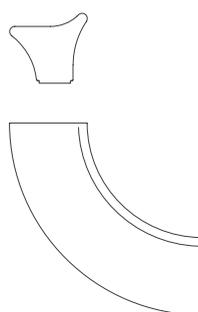

200 cm



**Ona C 90**

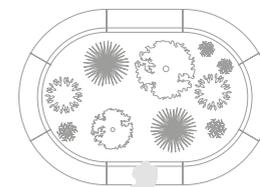

**Ona convexo  
Ona recto**



**Ona cóncavo  
Ona convexo**

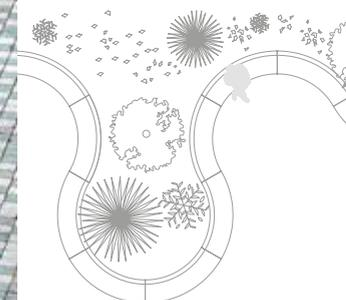



# Olive

by Bow Design



Olive OL light



Olive OB

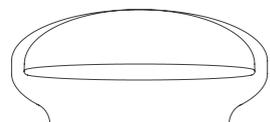

200 cm



270 cm



# Pausa

by Oriol Guimerà

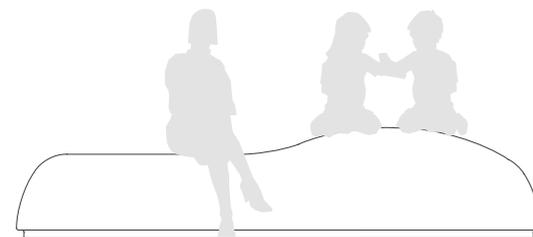

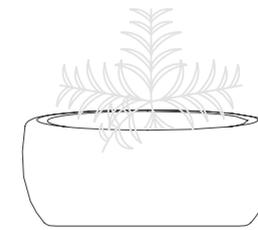
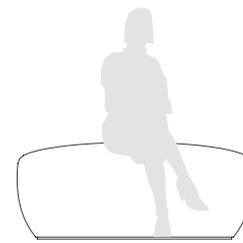

# Russes

by Kutarq studio + YHY design

Juega con volúmenes y deja volar tu creatividad.

Juga amb volums i deixa volar la teva creativitat.

*Play with volumes and let loose your creativity!*

*Jouez avec les volumes et laissez parler votre créativité.*



**Russes pouf**

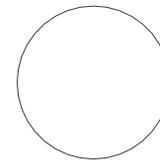

Ø 120 cm

**Russes J 71 | 88 L**



Ø 71 cm

**Russes J 130 | 210 L**

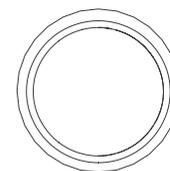

Ø 130 cm

**Russes B | 820 L**

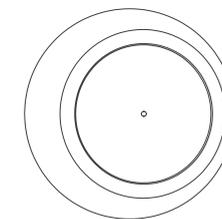
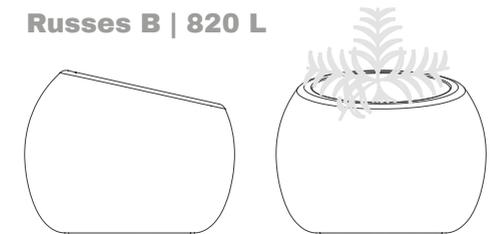

Ø 170 cm





Targa B 50, Targa T 77

# Targa

Una declaración clásica con una geometría simple y pura.

Una declaració clàssica amb una geometria simple i pura.

*A classic statement with simple, pure geometry.*

*Une déclaration classique avec une géométrie pure et simple.*



**Targa C**

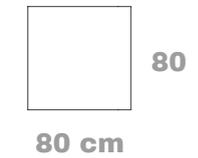
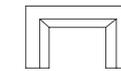

**Targa B 50**



**Targa B**



**Targa T 77  
Targa T 110**





# Tetris

by Roger Albero

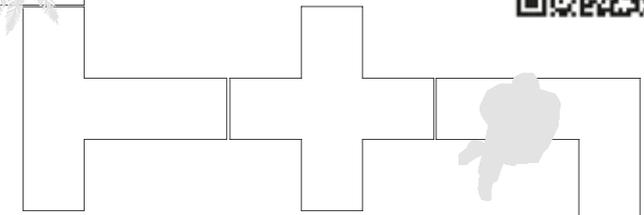
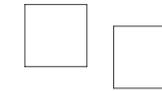
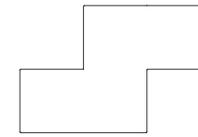

Para jugar, encajar y combinar en libertad.

Per jugar, encaixar i combinar en llibertat.

*To play, to fit together and to combine as you wish.*

*Pour jouer, assembler et combiner en toute liberté.*

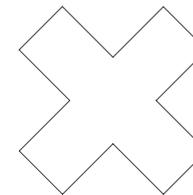
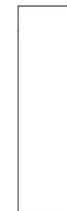

● Ver Accesorios, p. 240  
See Accessories, p. 240

**Tetris I 90 | Tetris I 150 | Tetris I 220**



90 | 150 | 220 cm

**Tetris Q | Tetris Q 90**



45 | 90 cm

**Tetris C**



**Tetris T**



**Tetris X**

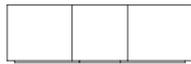

**Tetris O**

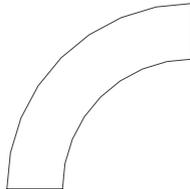

150 cm

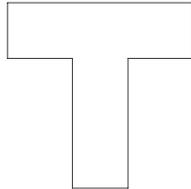

150 cm

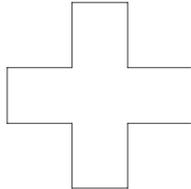

150 cm



150 cm

**Tetris L**



**Tetris Z1**



**Tetris Z2**



**Tetris O plus**

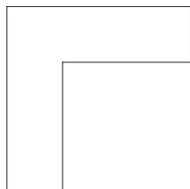

150 cm

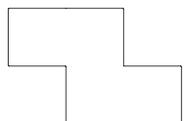

135 cm

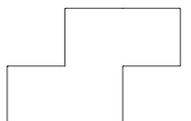

143 cm

**Tetris C30**



215 cm

**Tetris J 120 | 110 L  
Tetris J | 147 L**



120 | 150 cm

**Tetris L vertical | 150 L**



90



150 cm



Tetris \_ Roger Albero

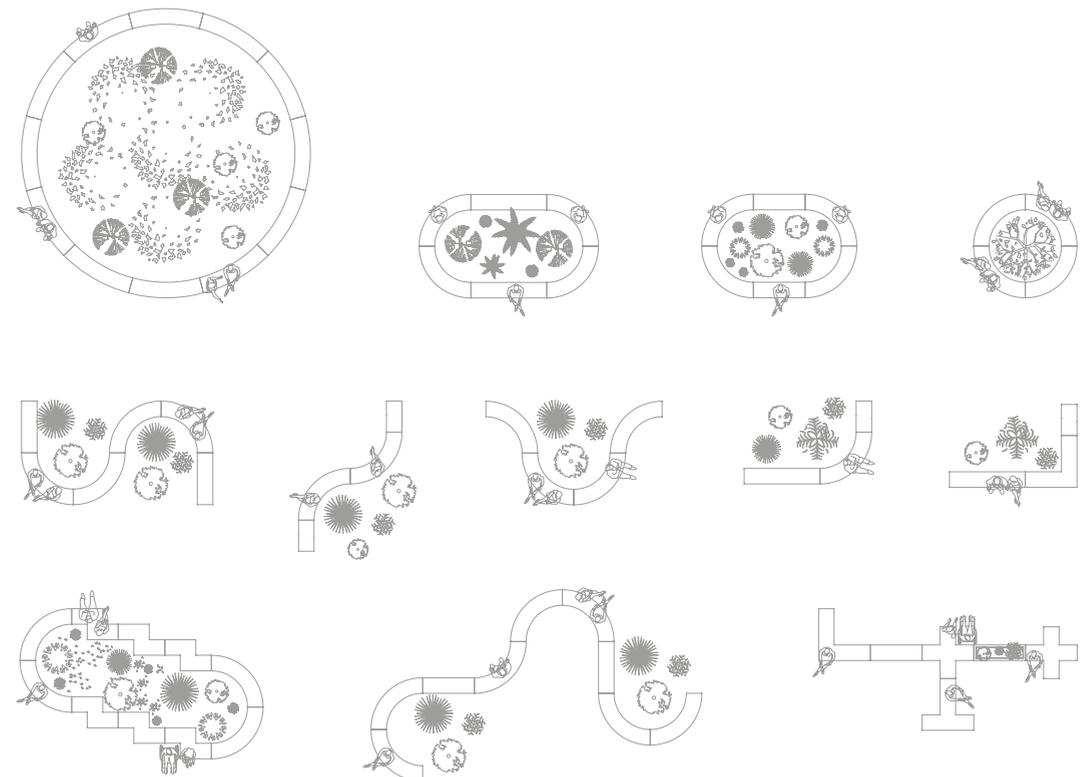

● Ver Accesorios, p. 240  
See Accessories, p. 240

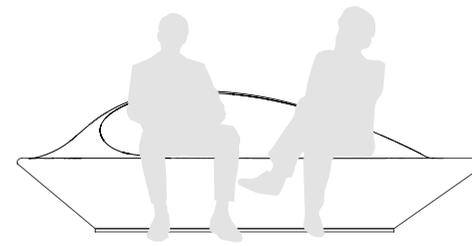

# Sassi

by Ton Riera

## Sassi J

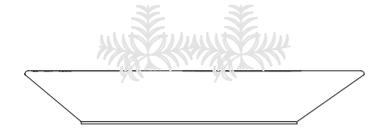

Barcas de hormigón ancladas en tierra firme.

Barques de formigó ancorades en terra ferma.

*Concrete boats anchored on land.*

*Bateaux en béton ancrés à terre.*

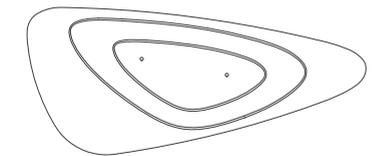

260 cm

## Sassi

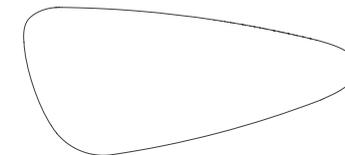

## Sassi R

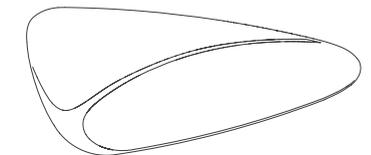

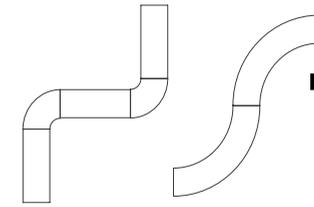
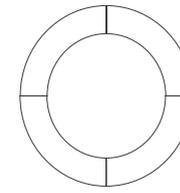
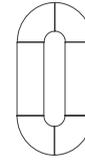
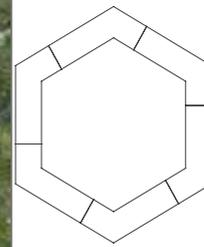

# Tippy

by Ton Riera

**Serie de elementos combinables para trazar límites y bancos de formas redondeadas y sensuales.**

*A serie of elements that can be combined to draw boundaries and benches with round and sensual shapes.*

**Sèrie d'elements combinables per traçar límits i bancs de formes arrodonides i sensuals.**

*Série d'éléments modulaires pour délimiter et former des bancs aux formes arrondies et sensuelles.*

**Tippy V**

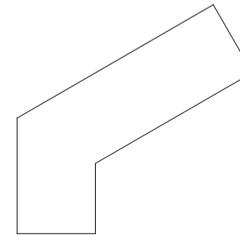

**Tippy B**



**110 | 160 | 220 cm**

**Tippy R 23**

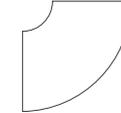

**Tippy R 136**

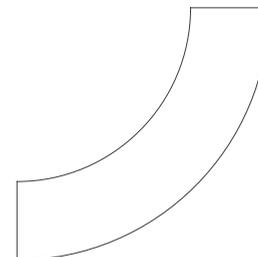

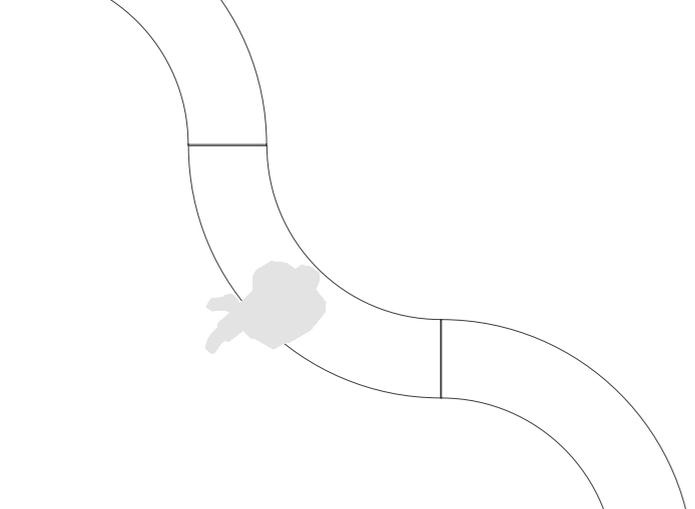

**Tippy gap B 220**



**220 cm**

**Tippy gap R 136**

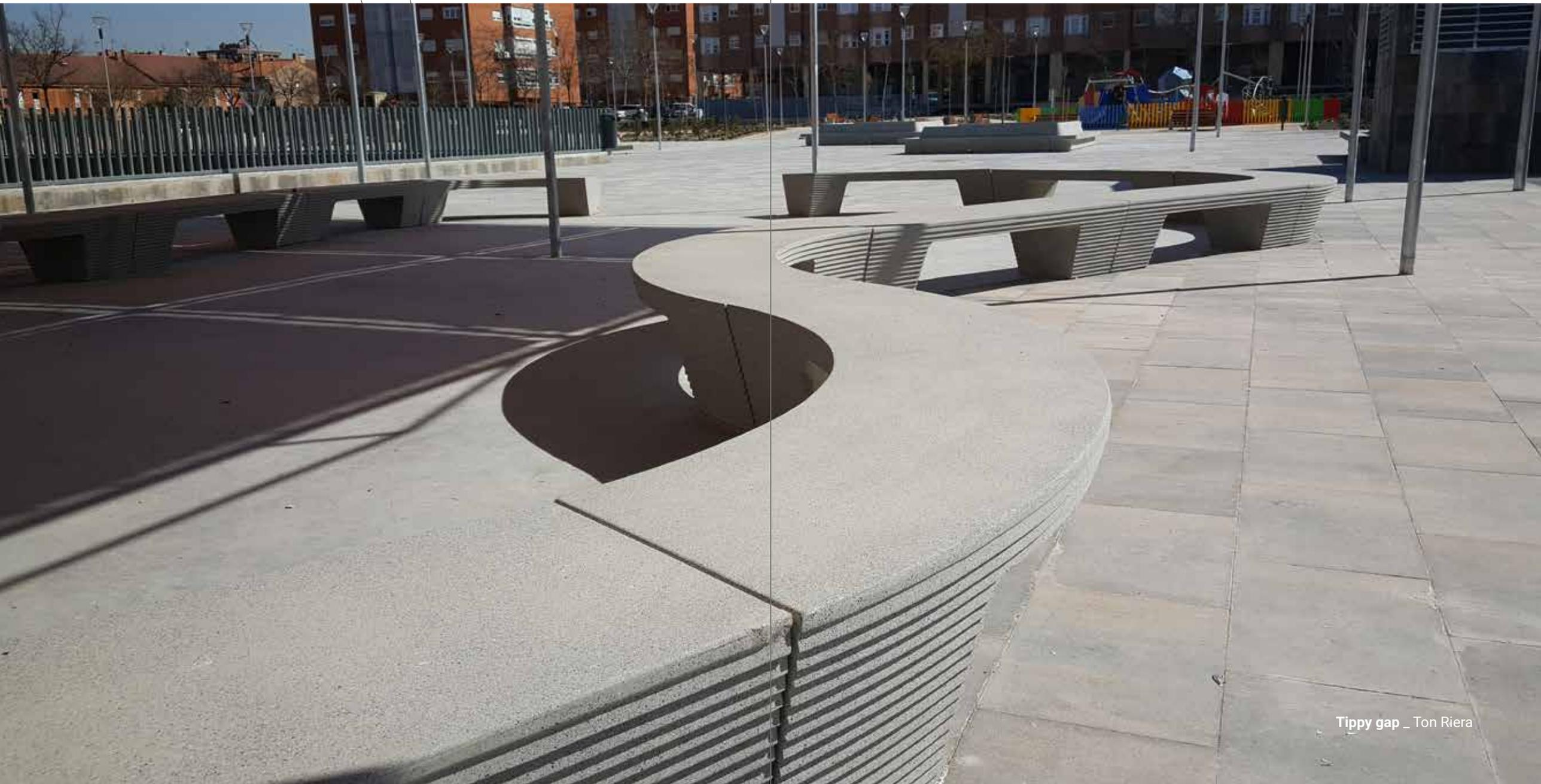
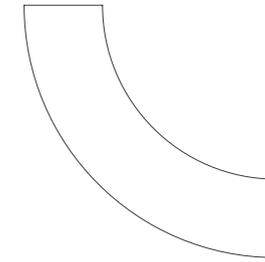



# Bloop

by Ton Riera

## Bloop 2m



200 cm

## Bloop 3m



300 cm

## Bloop 4m

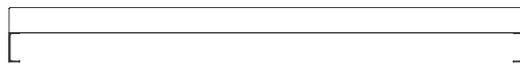

400 cm

## Bloop R

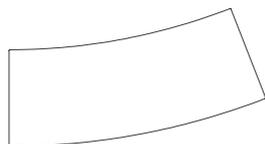

Elegancia y robustez en un mismo elemento.

Elegància i robustesa en un mateix element.

*Elegance and strength in the same piece.*

*Élégance et robustesse en un seul élément.*

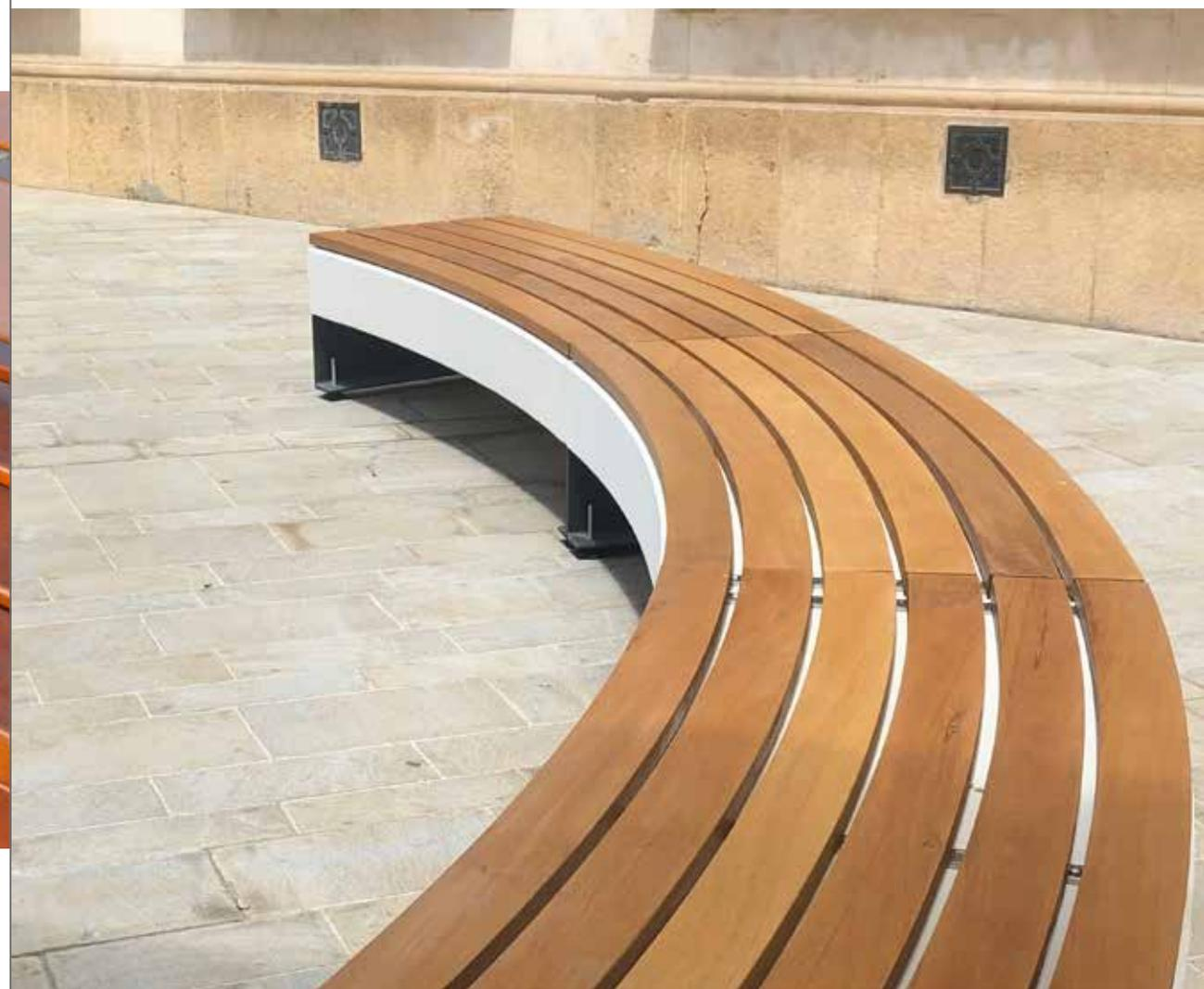

● Ver Accesorios, p. 240  
See Accessories, p. 240







# Practic

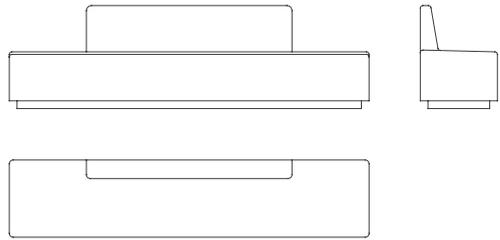

280 cm

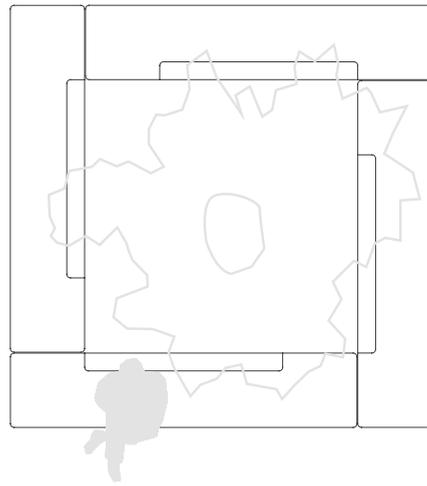

## Mesull



## Mesull SR



177 cm

# Mesull





# Tube

by Roger Albero

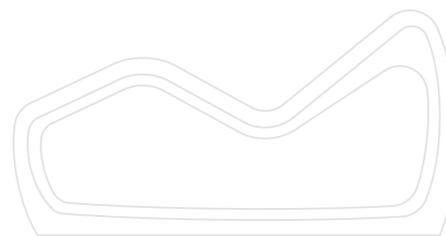

Esencial, mínimo, sólo una línea de hormigón y el espacio vacío.

*Essential, minimalist: just a line of concrete and an empty space.*

Essencial, mínim, només una línia de formigó i l'espai buit.

*Essentiel, minimaliste, juste une ligne de béton et de l'espace vide.*

**Tube silla**



80 cm

**Tube tumbona**

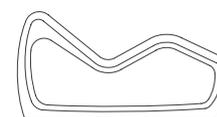

161 cm

**Tube banca**



164 cm

**Tube cubo**



60 cm

**Tube bike**



76 cm



# Vinyes

by EMBT / Benedetta Tagliabue

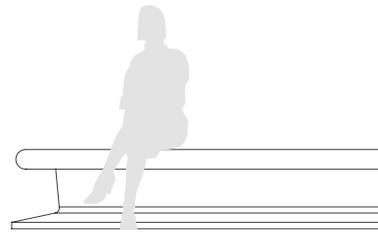
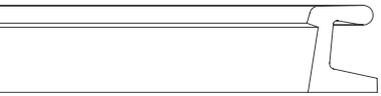

Banco, límite, barrera, muro de jardín... ordena el espacio.

*Bench, boundary, barrier, garden wall... to organise the space.*

Banc, límit, barrera, muret de jardí... ordena l'espai.

*Banc, limite, barrière, mur de jardin... pour ordonner l'espace.*



**Vinyes I 160**



160 cm



**Vinyes R 726**



**Vinyes R 333**

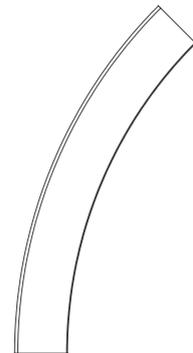
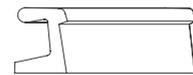

**Vinyes R 250**

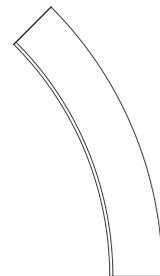
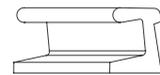

Iluminación LED opcional  
Optional LED lighting

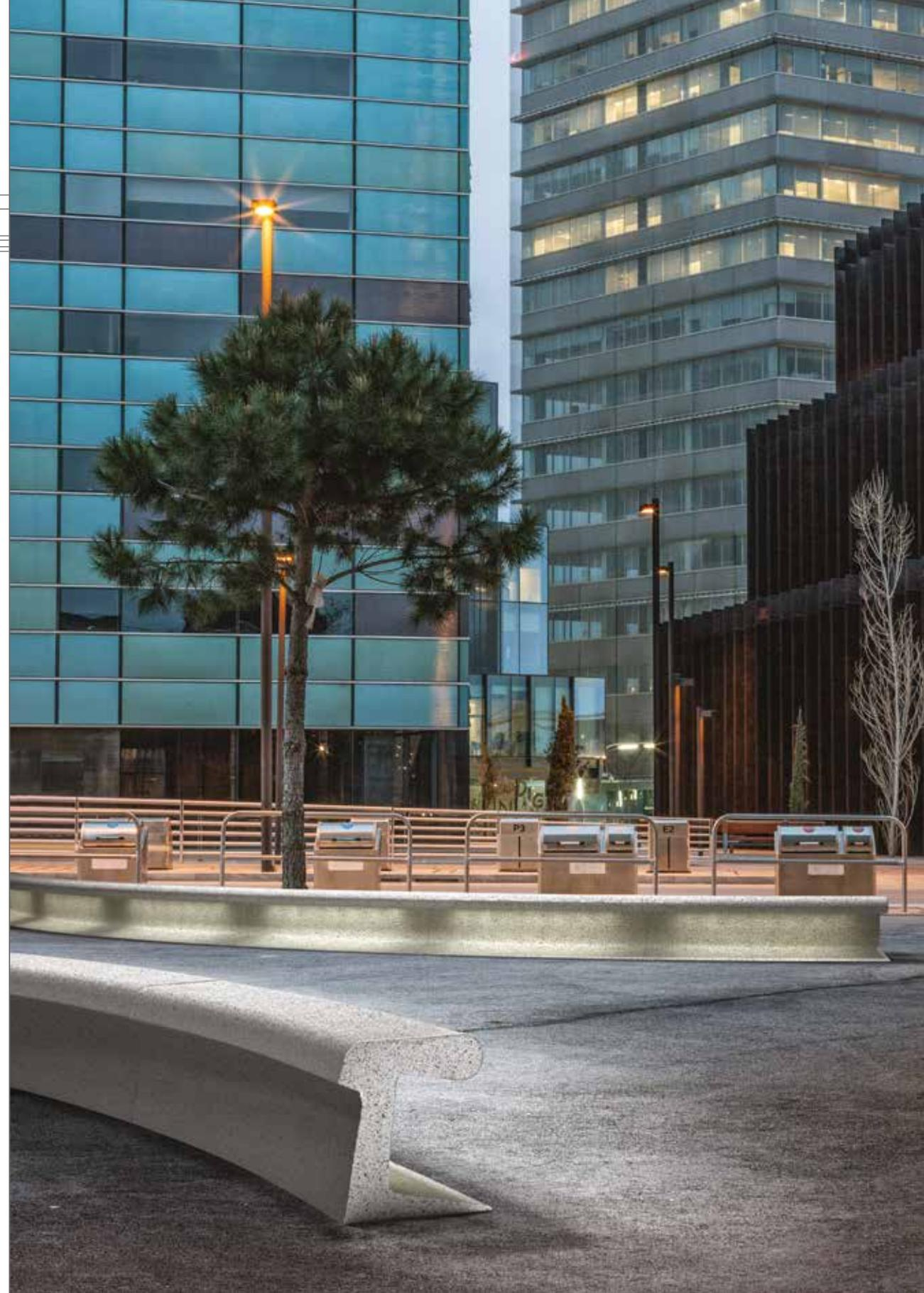

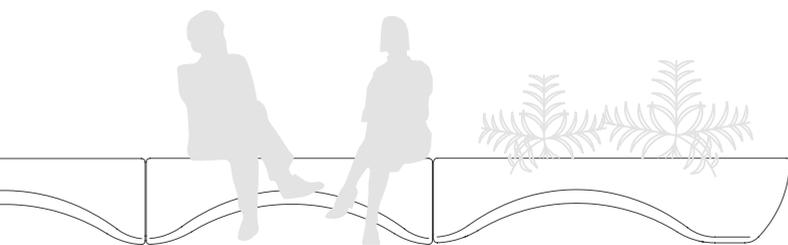

# Waves

by Roger Albero

## Waves B

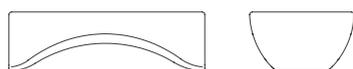

150 cm

Es un banco, es una jardinera, es un banco-jardinera. Para sentarse junto a la naturaleza.

És un banc, és una jardinera, és un banc-jardinera. Per seure vora la natura.

## Waves J | 295 L

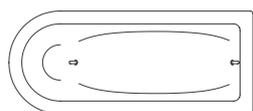

190 cm

*It's a bench. It's a planter. It's a bench-planter. To sit down next to nature.*

*C'est un banc, c'est une jardinière, c'est un banc-jardinière. Pour s'asseoir près de la nature.*



# Geométrico

by Cristina Noguera, Joaquim Roqué, Josep Motas

## Geométrico C

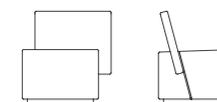

Ensalzando espacios para vivir, preciso y simétrico.

Enaltint espais per viure, precís i simètric.

*Exalting spaces to live, with its precision and symmetry.*

*Exaltation des espaces à vivre, grâce a sa forme précise et symétrique.*

## Geométrico B

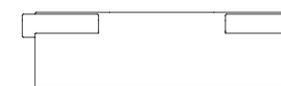
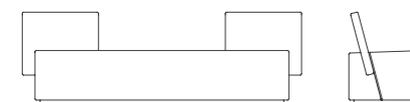

220 cm

# Zen

by los diez

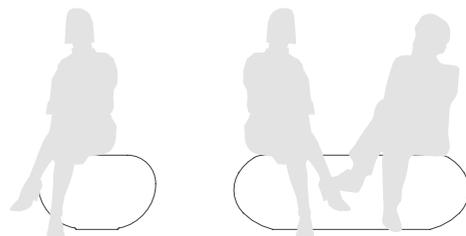

Elementos inspirados en los jardines zen, simplicidad elegante que invita a la calma.

Elements inspirats en els jardins zen, simplicitat elegant que convida a la calma.

*Elements inspired by Zen gardens; elegant simplicity that invites tranquility.*

*Des éléments inspirés par les jardins Zen, une simplicité élégante qui invite à la sérénité.*

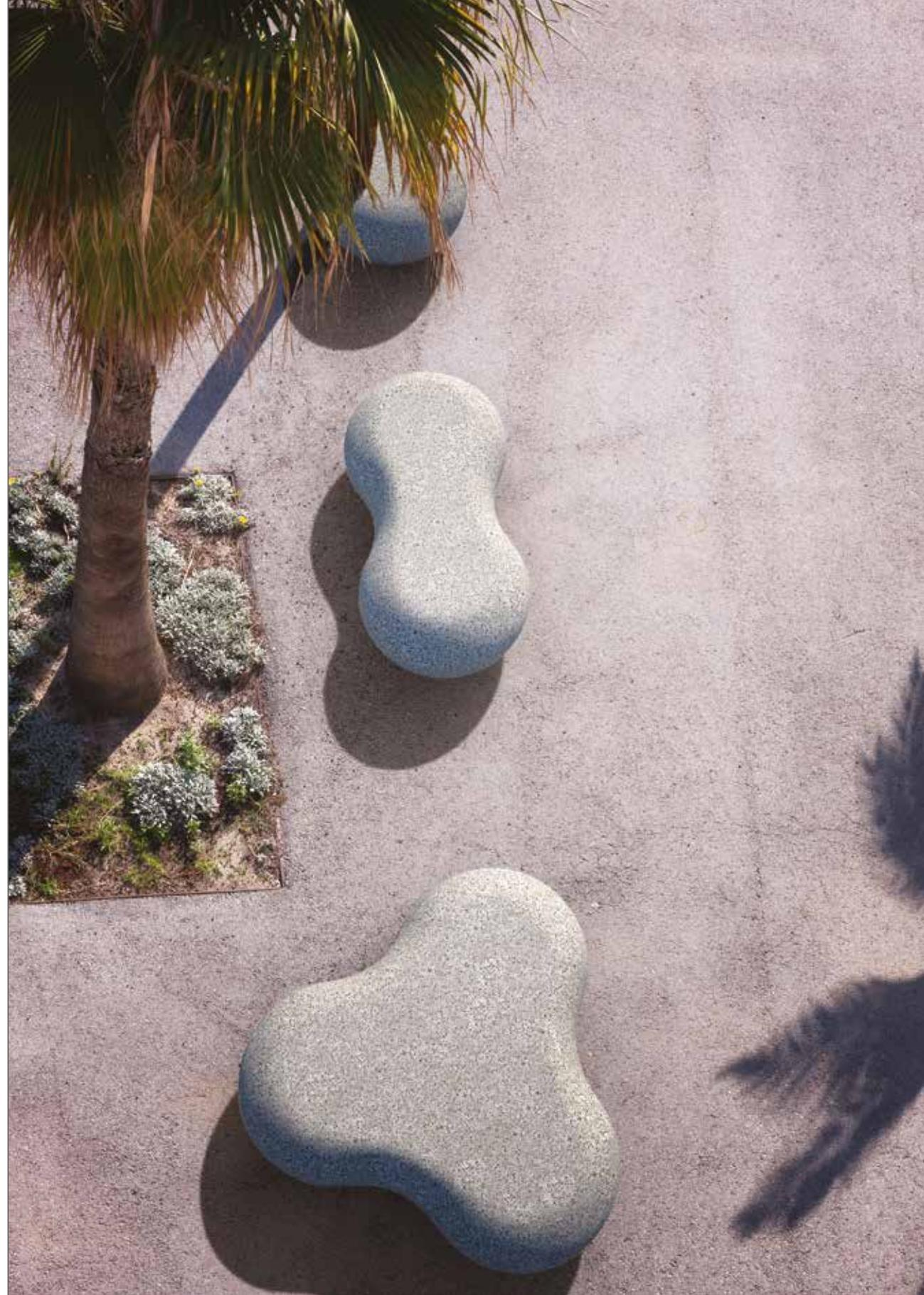



Zen V light \_ los diez

Zen V



Zen V light

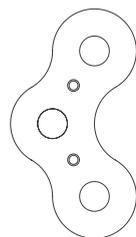
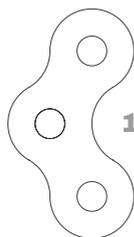

178 cm

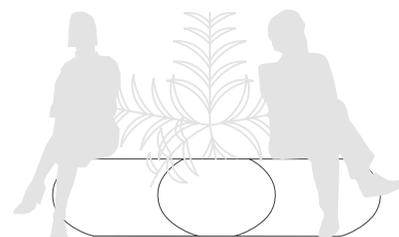
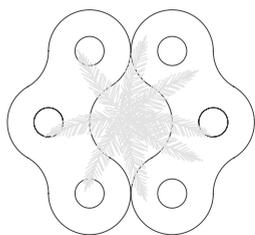

Zen



Ø 65 cm

Zen duo



130 cm

Zen trio

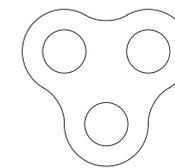

130 cm



colores | colors

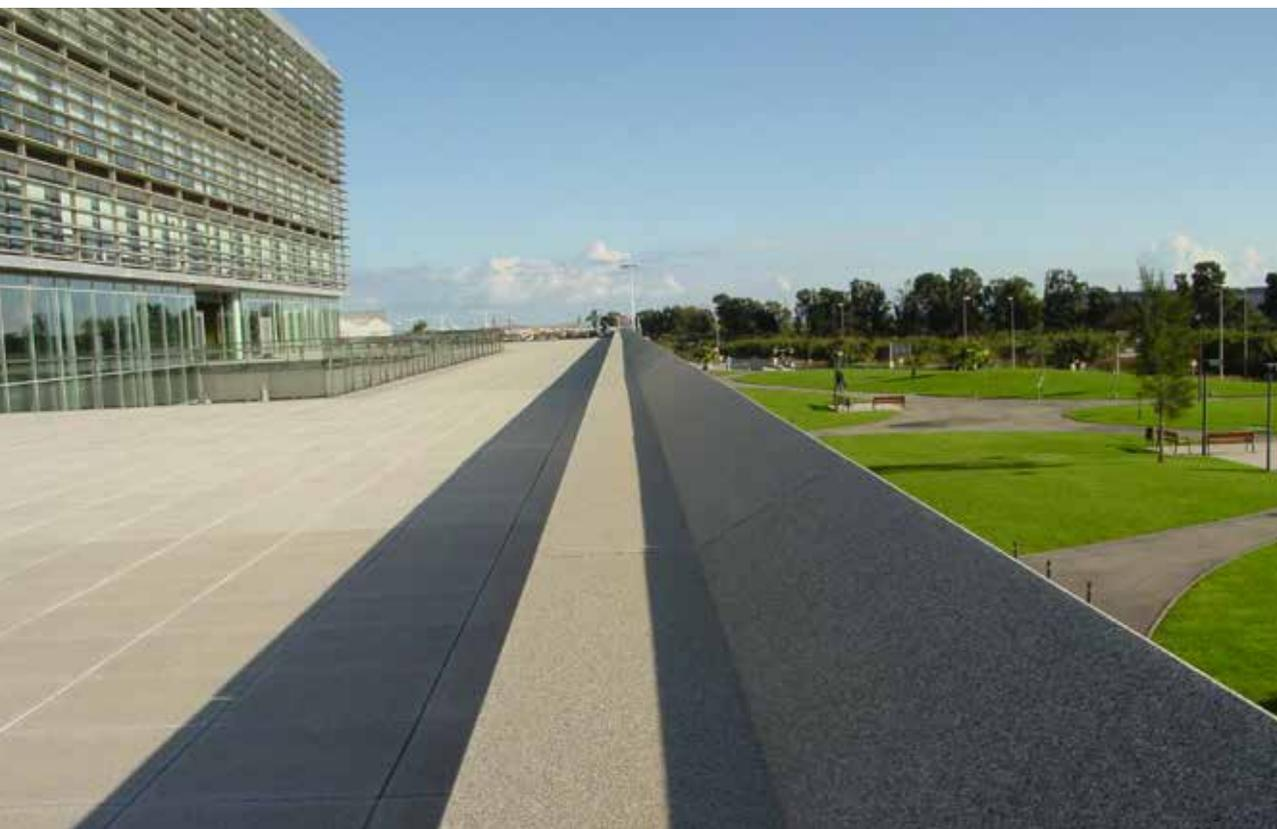

# Barrera

by GCA Arquitectes Associats

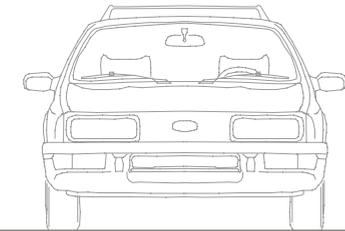
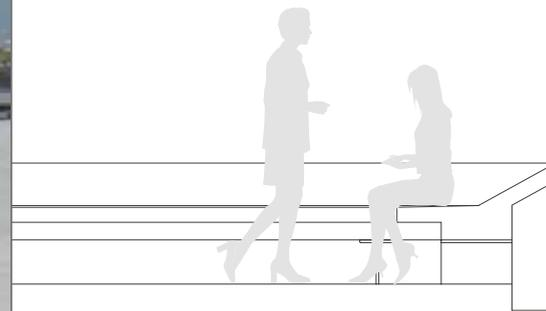

Líneas continuas, ligeras y de fuerte impacto sensorial.

Línies contínues, lleugeres i de fort impacte sensorial.

*Thin, continuous lines and a strong sensory impact.*

*Dont les lignes continues et légères génèrent un fort impact sensoriel.*



# Beta

by miba architects

## Beta 144



144 cm

## Beta 235



235 cm

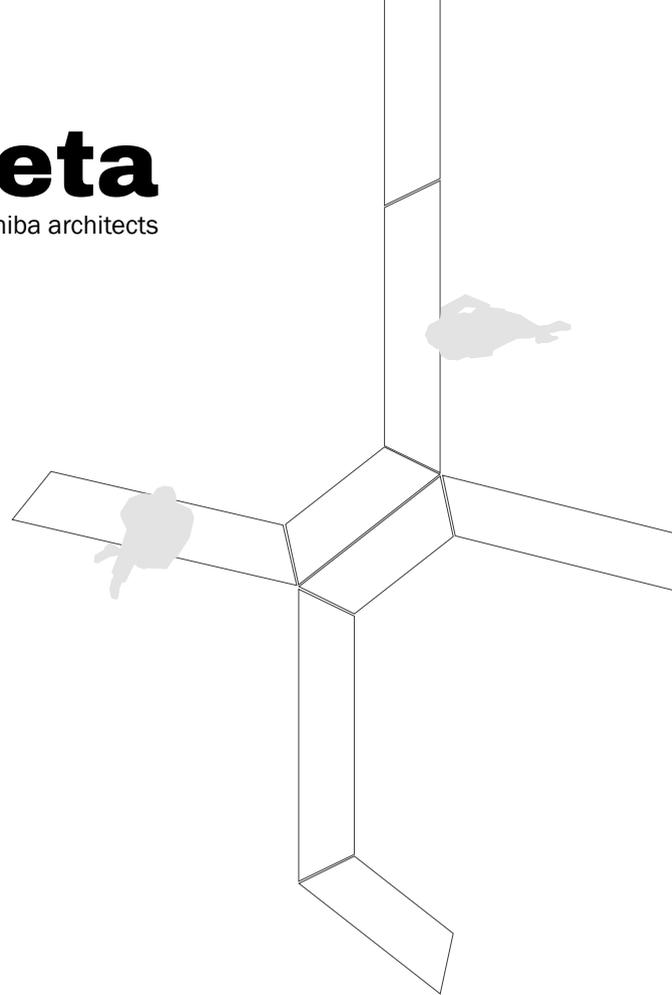





Dove pouf

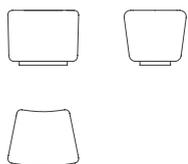

Dove cóncavo

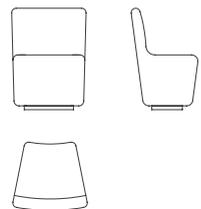

Dove convexo

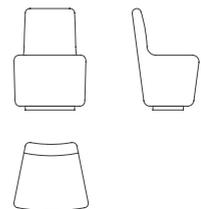

Dove J | 65 L

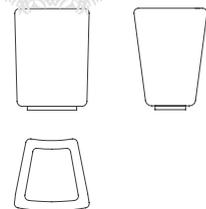

**Dove**  
by los diez

XIII  
PREMIOS  
AEPD

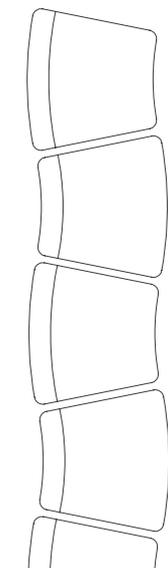



**Unió respaldo**

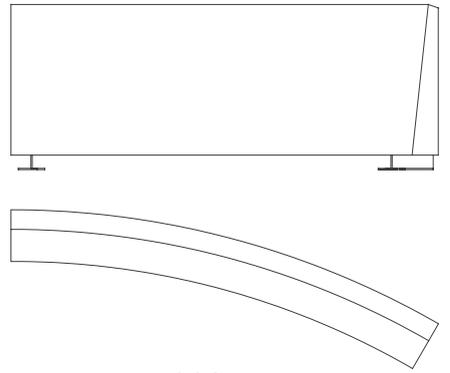

**322 cm**

**Unió asiento**

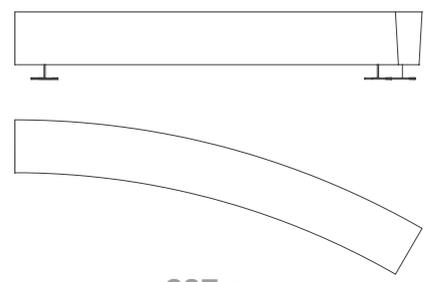

**307 cm**

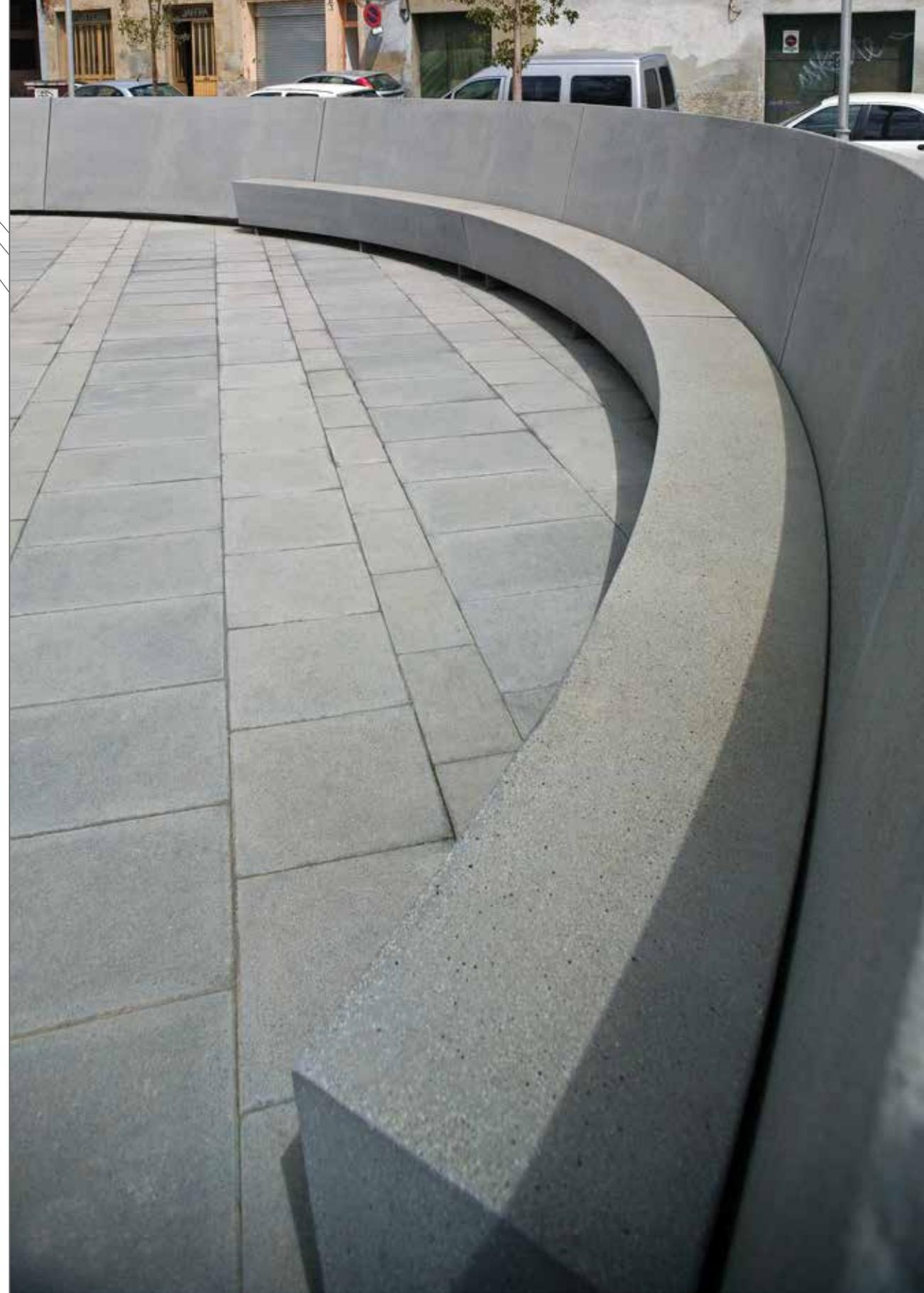
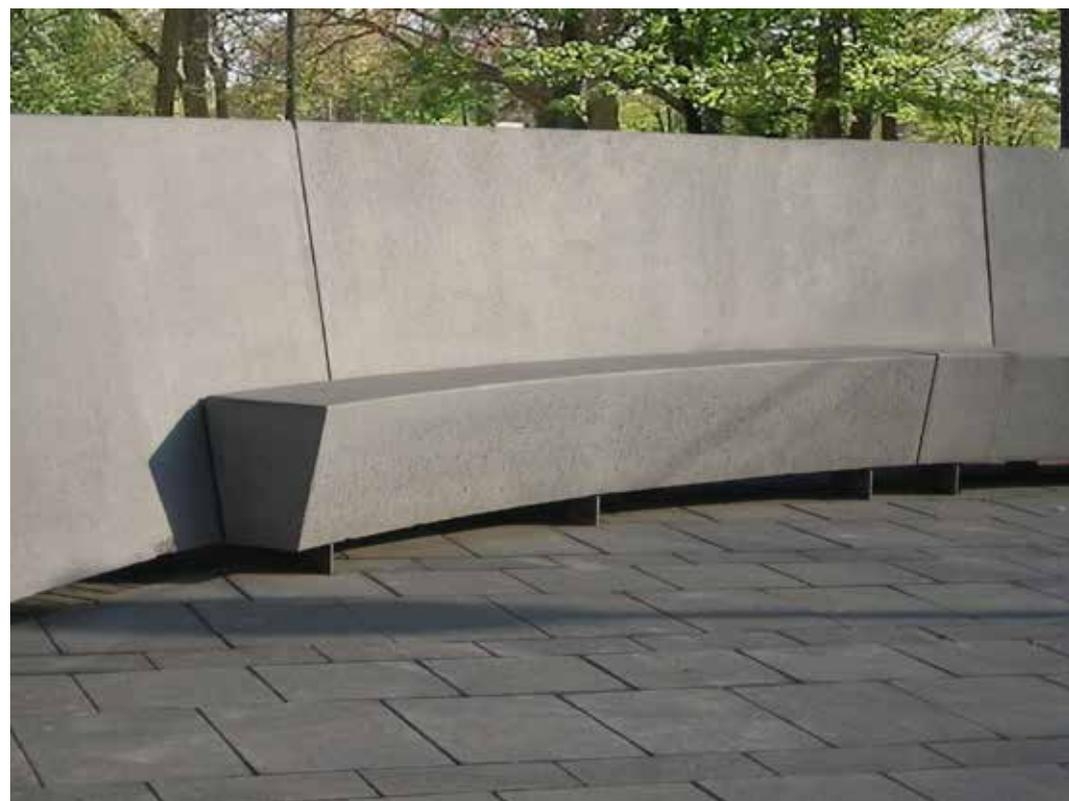



**Gandhi C**

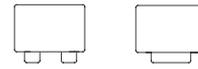

**Gandhi B**



**210 cm**

**Gandhi Combi | 270 L**

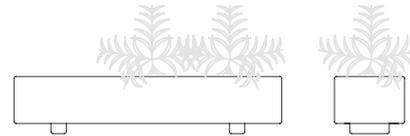

**210 cm**

# Gandhi

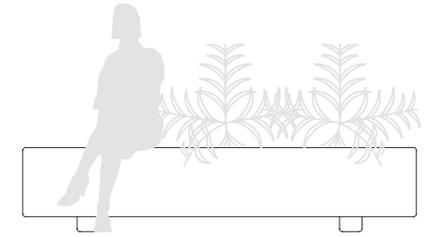

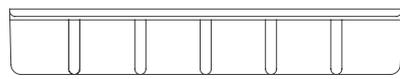
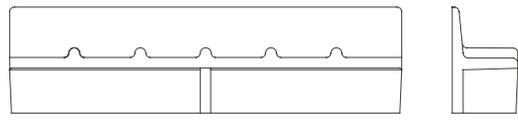

310 cm

**Nú**  
by Fante&Fabrè

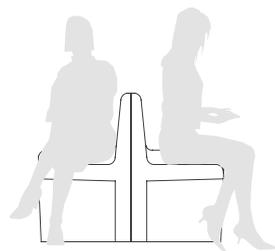

**Sore**



# Andra



400 cm



# MDT

by Ventura Valcarce

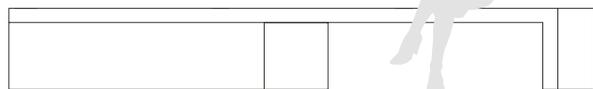

MDT non plus



320 cm



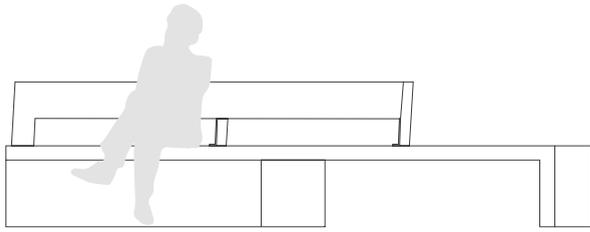

**MDT plus**

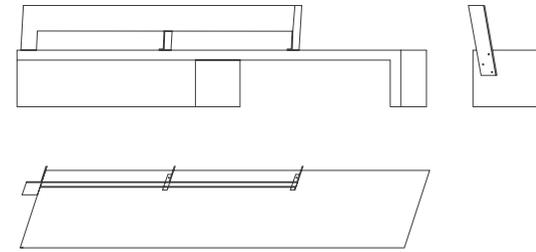

**320 cm**



# Sol



Sol 100  
Sol 140  
Sol 180

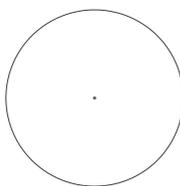

Ø 100 | 140 | 180 cm



# Modulblock



100

200 cm





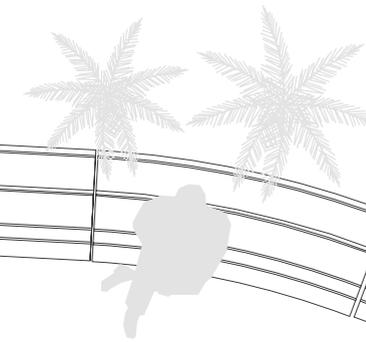

# Bécquer

by Javier Gorostidi, Bernardo del Pino

Recta, curva a la derecha, recta, curva a la izquierda, modula el espacio a tu gusto.

*Straight, turn to the right, straight, turn to the left; shape space to suit you.*

Recta, revolt a la dreta, recta, revolt a l'esquerra, modula l'espai al teu gust.

*Tout droit, courbe à droite, tout droit, courbe à gauche, modulez l'espace à votre goût.*

## Bécquer recto

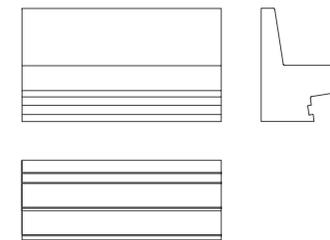

150 cm

## Bécquer cóncavo 4.7 | 14.7



## Bécquer convexo 4.7 | 14.7



## Bécquer A

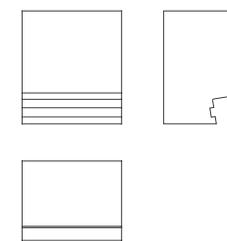

75 cm

## Bécquer A1

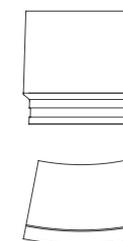

87 cm

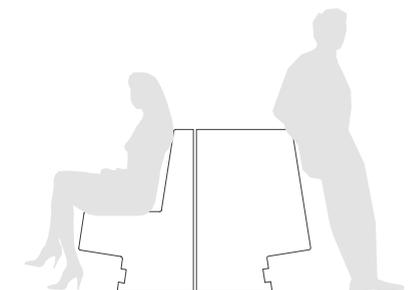



# Ponte

by los diez

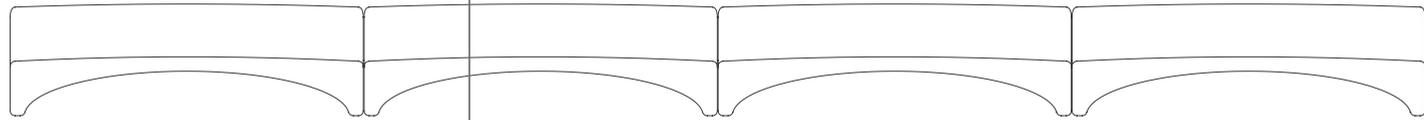
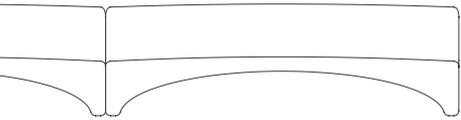

XIII  
PREMIOS  
AEPD



## Ponte C

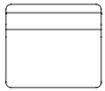
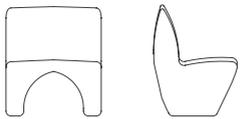

## Ponte B

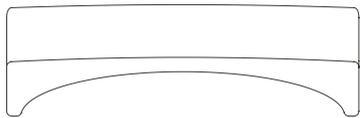

270 cm

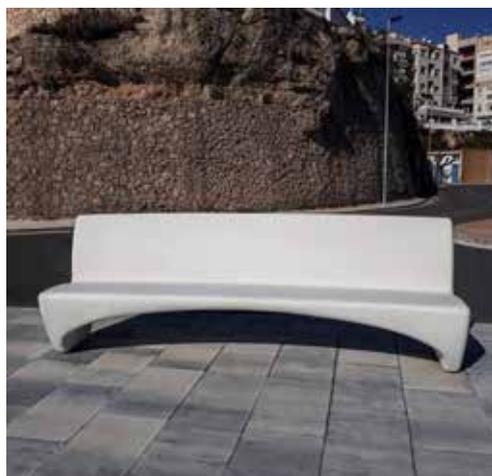

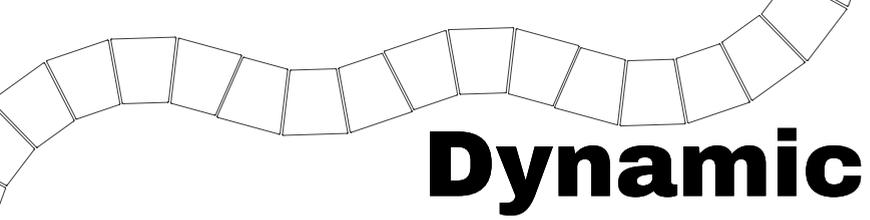

# Dynamic

**Dynamic Q 50**

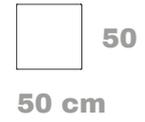

**Dynamic T 50**

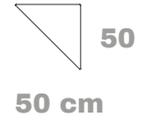

**Dynamic TR 50**



**Dynamic serp**

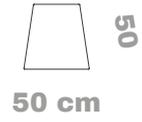

**Dynamic I 100**



**Dynamic I 150**

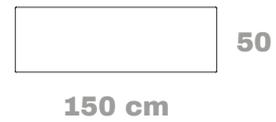

**Dynamic I 200**



**Dynamic six**

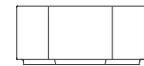

**Dynamic I 240**



**Dynamic I 260**



**Dynamic Q 30**



**Dynamic J 100 | 123 L**

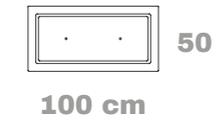
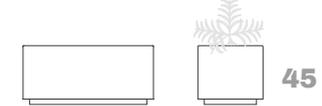

**Dynamic J 200 | 265 L**

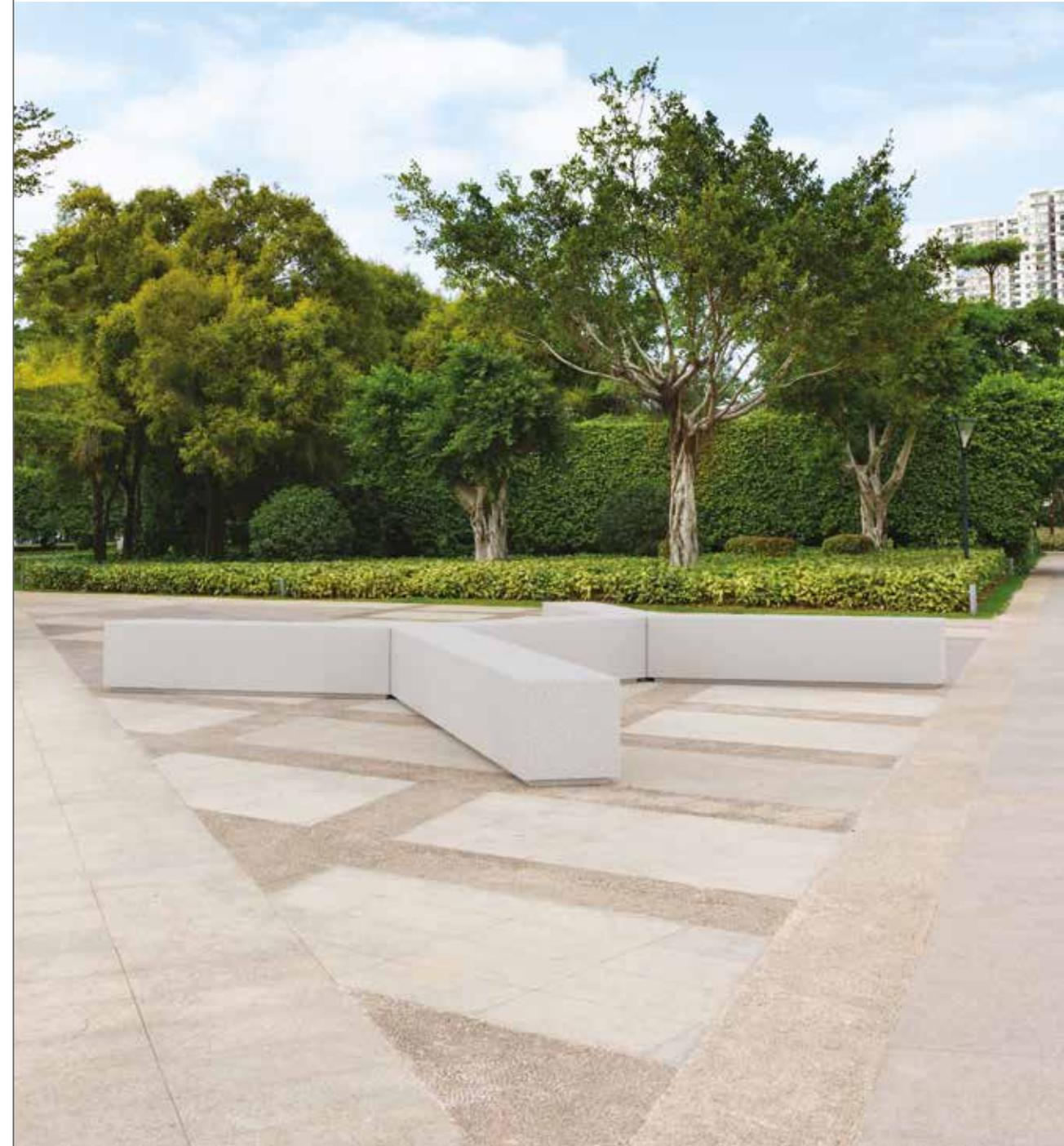
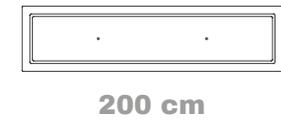

● Ver Accesorios, p. 240  
See Accessories, p. 240

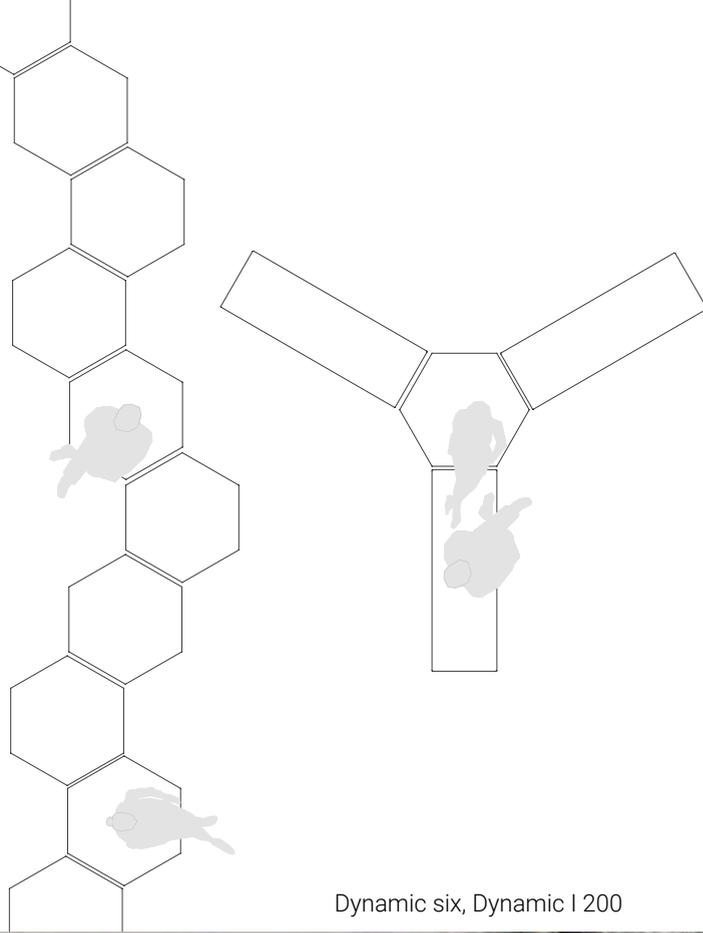
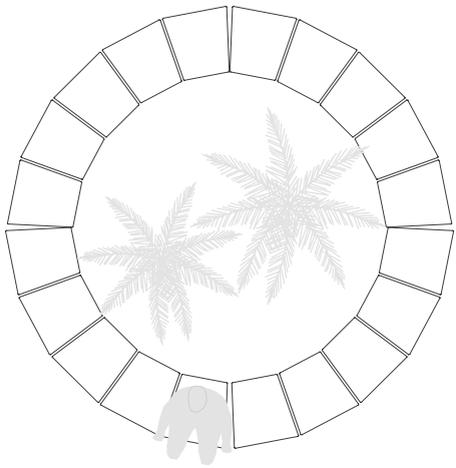

Dynamic six, Dynamic I 200

**Dynamic I 200 tuc**



50

200 cm

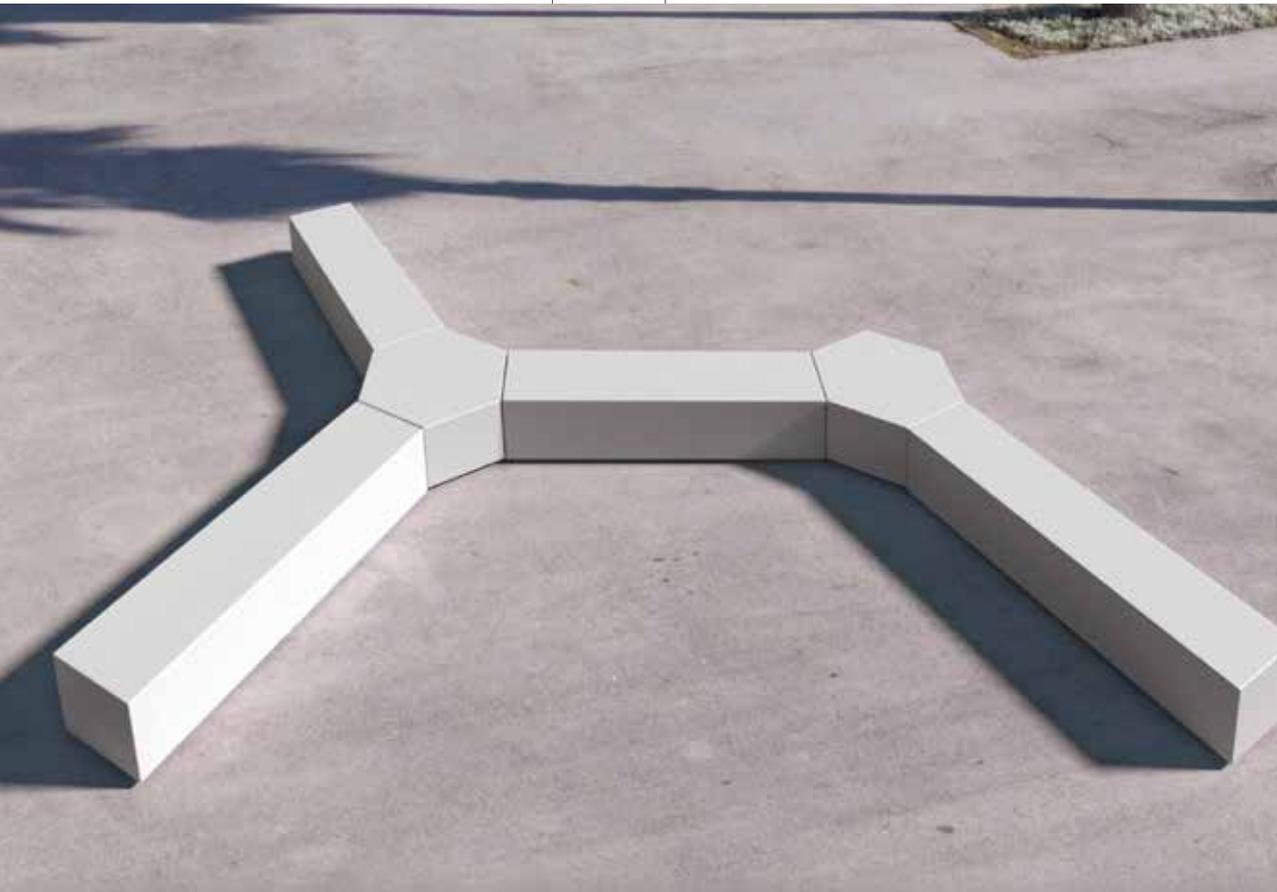
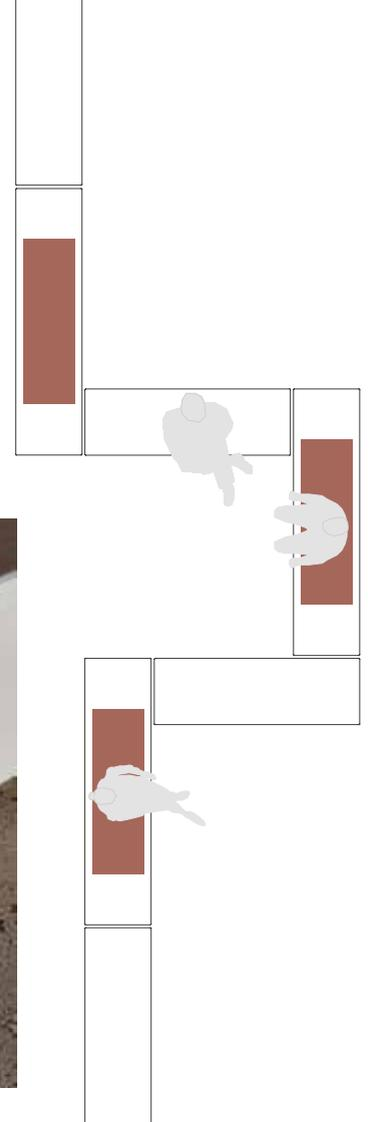

Dynamic I 200 tuc

**Dynamic Q 100**



**Dynamic T 100**



**Dynamic XL 300**



**Dynamic XL 400**



▶ Ver papeleras Dynamic, p. 180  
See Dynamic litter bins, p. 180

● Ver Accesorios, p. 240  
See Accessories, p. 240



100

100 cm

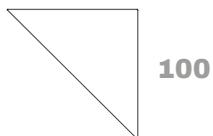

100

100 cm

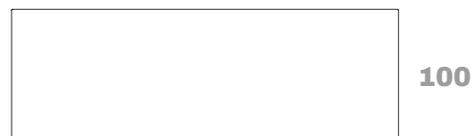

100

300 cm



100

400 cm



Dynamic Q 100, Dynamic T 100, Dynamic XL 300 + Plus 1



▶ Ver jardineras Hat, p. 164  
See Hat planters, p. 164

# Gant



# Hat

by Benditas

## Hat B 62



Ø 62 cm

## Hat B 150



Ø 150 cm

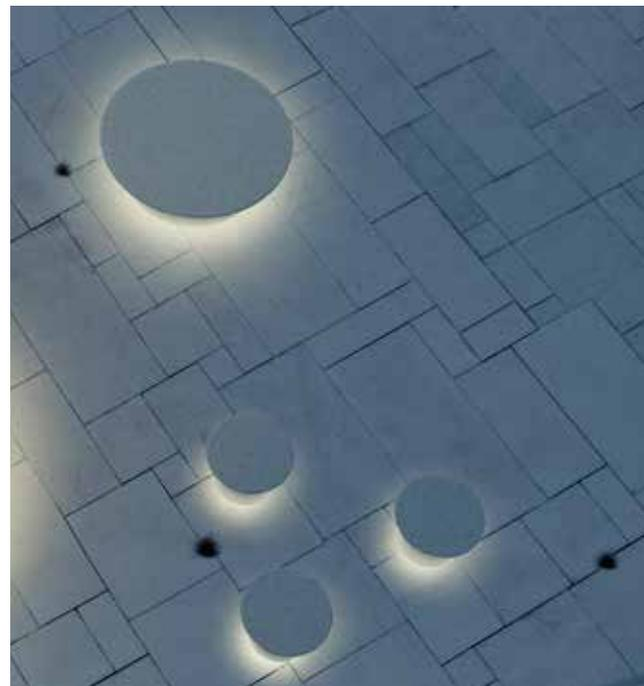

 Iluminación LED opcional  
Optional LED lighting

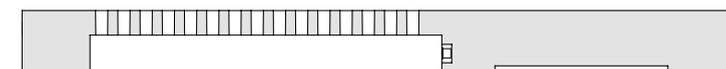
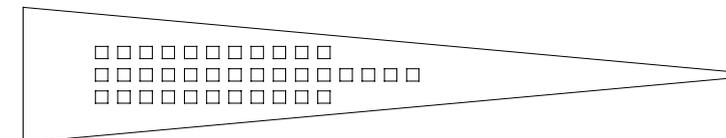

580 cm



110



# Bus

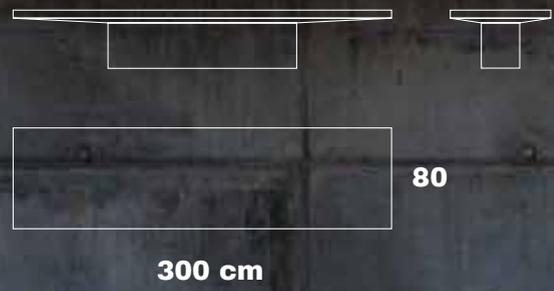



jardineras  
jardineres  
*planters*  
*jardinières*



# Smart watered,

## low-maintenance sustainable irrigation system



**MÁXIMO APROVECHAMIENTO DEL AGUA DE LLUVIA**  
MAXIMUM UTILIZATION OF RAINWATER



**80% AHORRO EN EL CONSUMO DE AGUA DE RIEGO**  
80% SAVINGS ON IRRIGATION WATER CONSUMPTION



**ÓPTIMO GRADO DE HUMEDAD DEL SUSTRATO**  
OPTIMAL GRADE OF SUBSTRATE'S HUMIDITY



**MÍNIMA INTERVENCIÓN DE LAS BRIGADAS DE MANTENIMIENTO:**  
AHORRO DE COMBUSTIBLE Y REDUCCIÓN DE LA CONTAMINACIÓN  
MINIMUM INTERVENTION OF MAINTENANCE BRIGADES:  
SAVINGS ON FUEL SPENDING AND POLLUTION REDUCTION

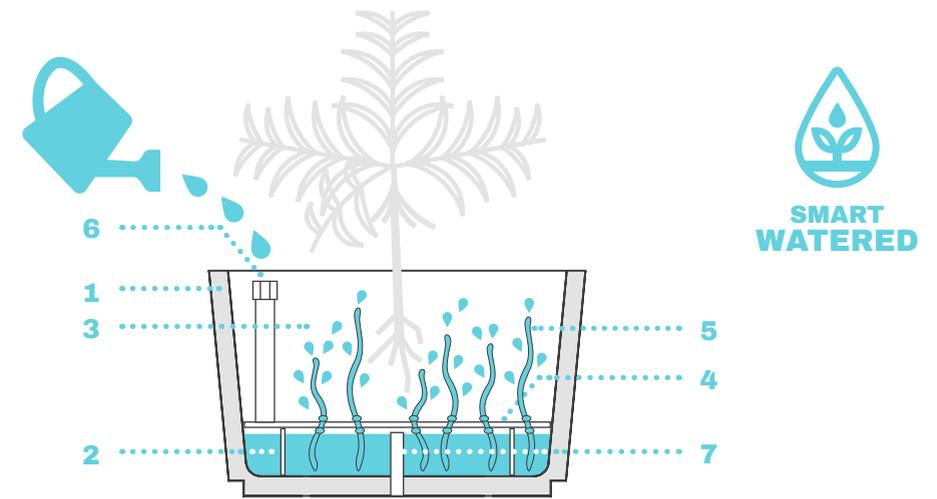

- 1** Jardinera MAGOURBAN compatible con el sistema SMART WATERED. Revestimiento interior a base de resina epoxi de dos Componentes, sin disolventes.

*MAGOURBAN planter compatible with SMART WATERED system. Interior coating made of a two component epoxy resin with no solvers.*

- 2** Depósito de agua: acumula agua a través del conducto de entrada de agua de riego.

*Water storage: stores water through the entrance conducts of irrigation water.*

- 3** Sustrato y plantas.

*Substrate and plants.*

- 4** Chapa metálica galvanizada de separación entre el depósito de agua y el sustrato, apoyada sobre patas metálicas.

*Galvanized metallic sheet separating the water deposit from the substrate, supported with metallic legs.*

- 5** Cuerdas de esparto que permiten el ascenso, por capilaridad, del agua del depósito hacia el sustrato.

*Esparto ropes which allow water to ascend, due to capillarity, from the deposit towards the substrate.*

- 6** Conducto de entrada de agua de riego, con tapa roscada. Marcador de bola inferior, visible desde el exterior, que mide el nivel de agua, indicando la necesidad de riego.

*Entrance conduct for irrigation water, with a screw cap. Inferior dial indicator, visible from the outside, to measure the level of water and signal the need of irrigation.*

- 7** Tubo de salida de agua sobrante y ventilación para evitar la putrefacción del agua estancada.

*Outlet tube for remaining water and ventilation to avoid putrefaction of stagnant waters.*

Jardinera MAGOURBAN compatible amb el sistema SMART WATERED. Revestiment interior a base de resina epoxi de dos Components, sense disolvents.

*Jardinière MAGOURBAN, compatible avec le système SMART WATERED. Revêtement intérieur à base de résine époxy de deux composants, sans dissolvant.*

Dipòsit d'aigua: acumula aigua mitjançant el conducte d'entrada d'aigua de reg.

*Réservoir d'eau: Accumule l'eau à travers des conduits d'entrée d'eau d'irrigation.*

Substrat i plantes.

*Substrat et plantes.*

Xapa metàl·lica galvanitzada de separació entre el dipòsit d'aigua i el substrat, recolzada sobre potes metàl·liques.

*Plaque métallique galvanisée de séparation entre le réservoir d'eau et le substrat, appuyée sur des pieds métalliques.*

Cordes d'espart que permeten la pujada, per capil·laritat, de l'aigua del dipòsit cap al substrat.

*Cordes en sparte qui permettent la montée par capillarité de l'eau du réservoir vers le substrat.*

Conducte d'entrada d'aigua de reg, amb tapa cargolada. Marcador de bola inferior, visible des de l'exterior, que mesura el nivell d'aigua, indicant la necessitat de reg.

*Conduit d'entrée d'eau d'irrigation, avec bouchons à visse. Indicateur de boule inférieure, visible depuis l'extérieur et qui mesure le niveau d'eau en indiquant la nécessité d'irriguer.*

Tub de sortida d'aigua residual i ventilació per evitar la putrefacció de l'aigua estancada.

*Tube de sortie d'eau restant et ventilation pour éviter la putréfaction de l'eau retenue.*

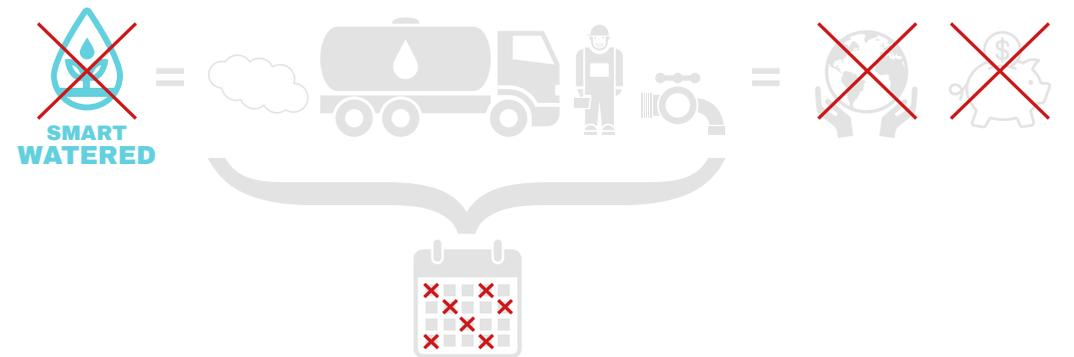
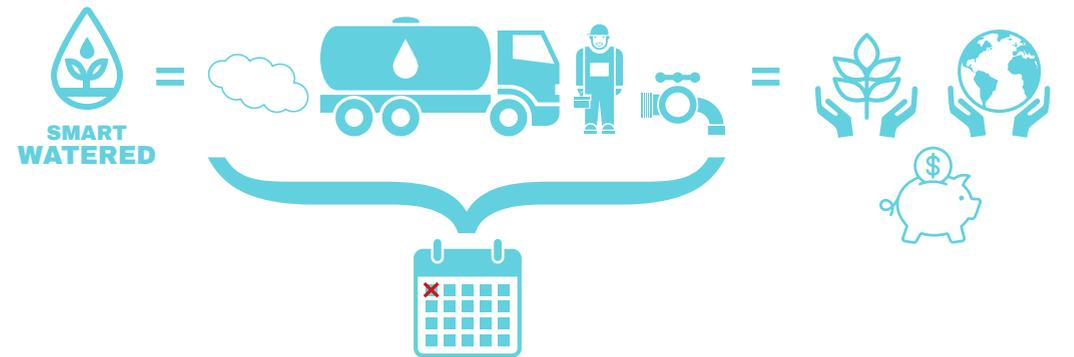
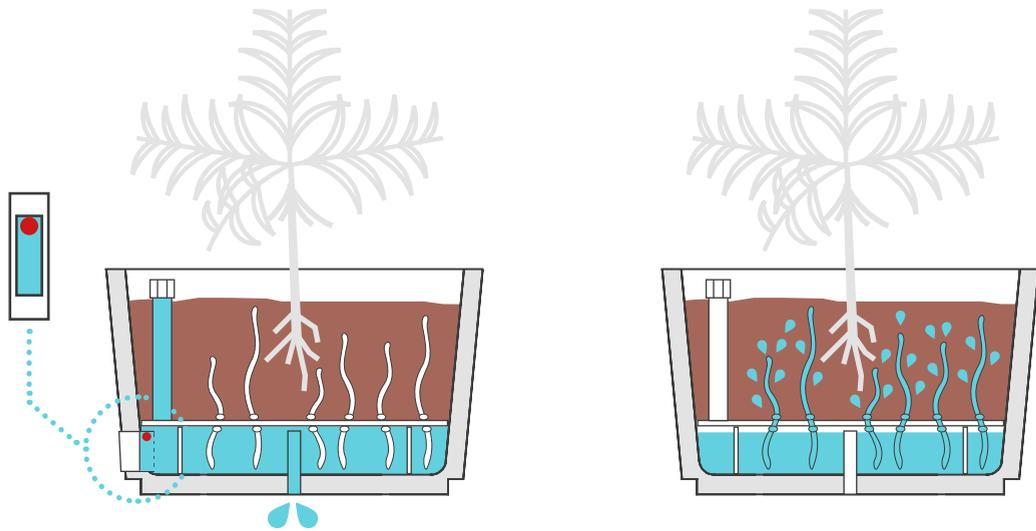
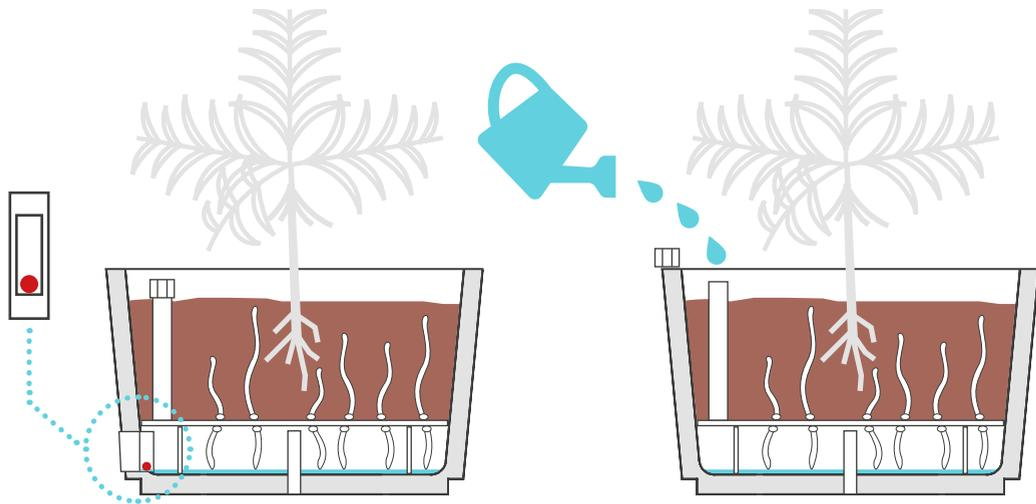

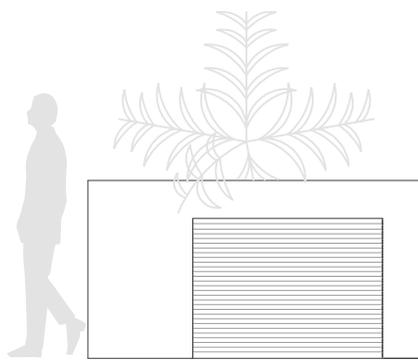

# Tanit

by Ton Riera

Jardineras en diferentes formatos que por sus líneas sobrias y elegantes encajan en cualquier ambiente. El modelo Tanit L, es actualmente, la jardinera de mayor capacidad del mercado.

*Planters in different formats with simple, elegant lines that allow them to blend seamlessly into any setting. The Tanit L is the largest-capacity planter on the market today.*

Jardineras en diferents formats que per les seves línies sòbries i elegants s'integren en qualsevol ambient. El model Tanit L, és actualment, la jardinera amb més capacitat del mercat.

*Jardinières de différentes tailles dont les lignes sobres et élégantes s'intègrent à tous les environnements. Le modèle Tanit L est actuellement la jardinière avec la plus grande capacité sur le marché.*

**Tanit S | 140x42x60(h) cm | 145 L**



<b>Tanit SP</b>	<b>100x100x90(h) cm</b>	<b>620 L</b>
<b>Tanit SM</b>	<b>120x120x80(h) cm</b>	<b>620 L</b>
<b>Tanit M</b>	<b>150x150x80(h) cm</b>	<b>1.040 L</b>
<b>Tanit L 60</b>	<b>190x190x60(h) cm</b>	<b>1.100 L</b>
<b>Tanit L 80</b>	<b>190x190x80(h) cm</b>	<b>1.510 L</b>
<b>Tanit L 115</b>	<b>190x190x115(h) cm</b>	<b>2.315 L</b>

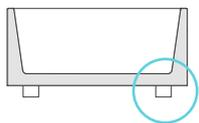
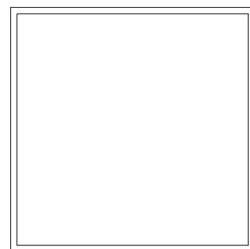
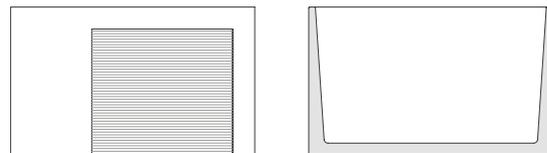

● Patas opcionales  
Optional legs

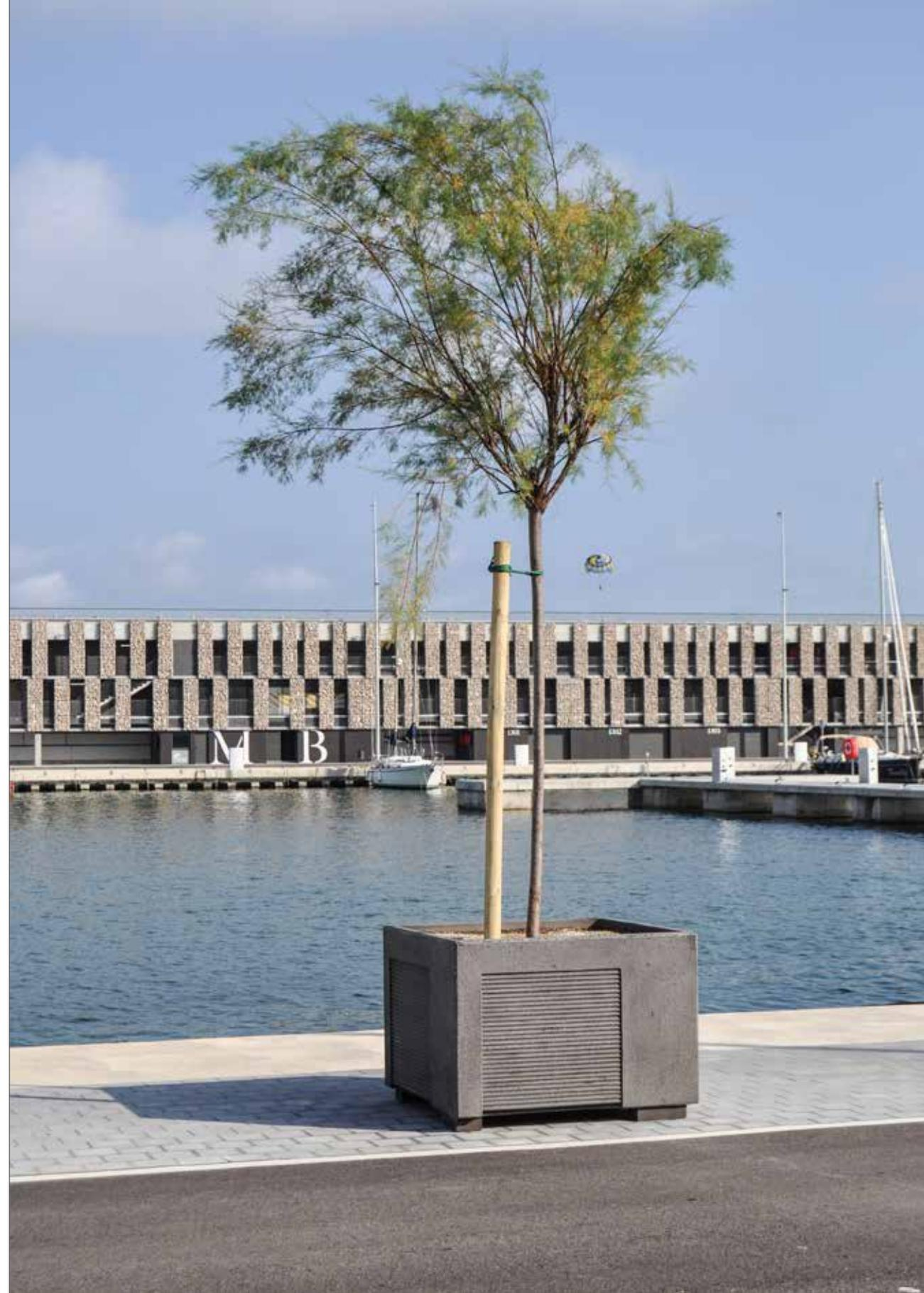



# Koniq



**Koniq JRA 100 | 360 L**

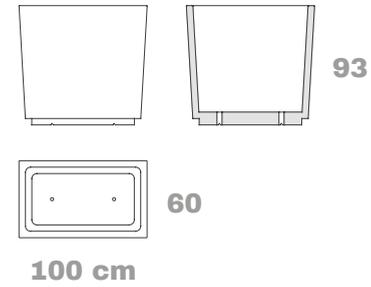

**Koniq JR 120 | 265 L**

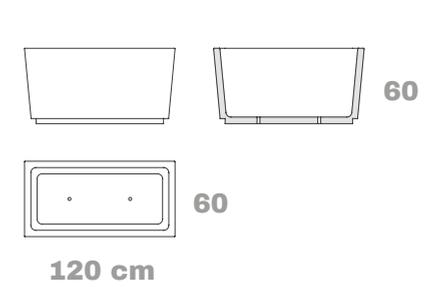

**Koniq JQ 60 | 155 L**

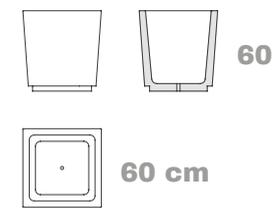

**Koniq JQ 90 | 438 L**

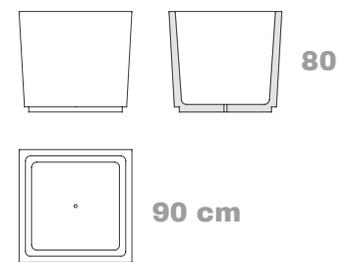

**Koniq JQ 120 | 837 L**

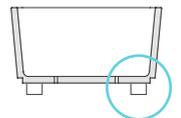
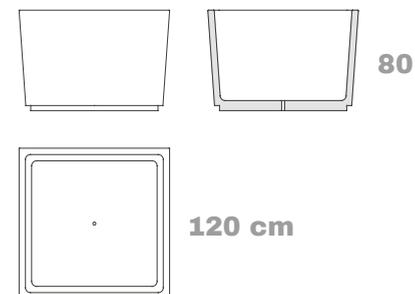

● Patas opcionales  
Optional legs



Koniq JQ 60, Koniq JQ 90

# Cantorodado

by Stimulo

Modeladas sin aristas como si la misma naturaleza las hubiera erosionado.

*Rounded design, as if eroded by nature itself.*

Modelades sense arestes com si la mateixa natura les hagués erosionat.

*Modelée sans bords comme si elle avait été érodée par la nature elle-même.*

Cantorodado 100 | 146 L

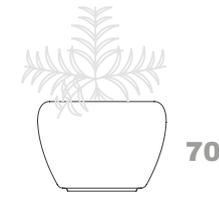

70

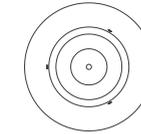

Ø 100 cm

Cantorodado 200 | 742 L

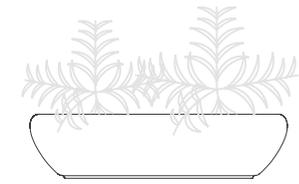

50

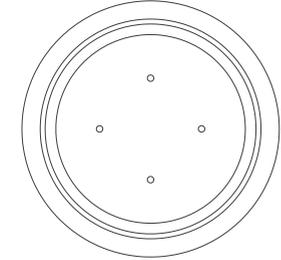

Ø 200 cm





# Fuat

by Ton Riera

Fuat R 60 | 150x43x60(h) cm | 250 L  
 Fuat R 80 | 150x52x80(h) cm | 400 L  
 Fuat S 85 | 150x80x80(h) cm | 600 L

Fuat R 60 P | 150x43x69(h) cm | 250 L  
 Fuat R 80 P | 150x52x89(h) cm | 400 L  
 Fuat S 85 P | 150x80x89(h) cm | 600 L

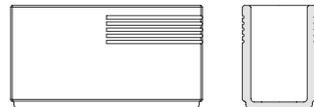
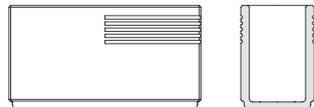

Fuat Q 60 | 162x162x60(h) cm | 1.150 L  
 Fuat Q 80 | 162x162x80(h) cm | 1.570 L

Fuat Q 60 P | 162x162x69(h) cm | 1.150 L  
 Fuat Q 80 P | 162x162x89(h) cm | 1.570 L

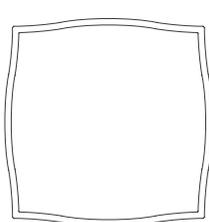
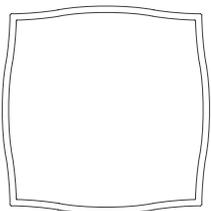
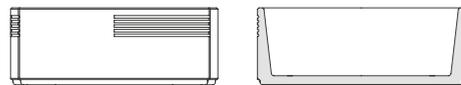
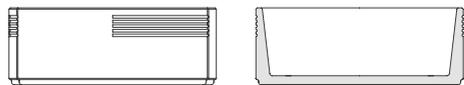

Hex 175 A | 580 L

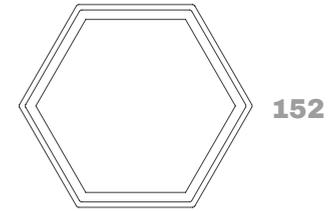

Hex 175 Base | 520 L

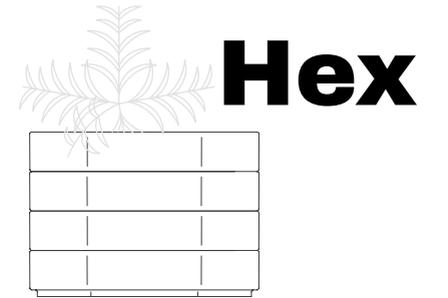
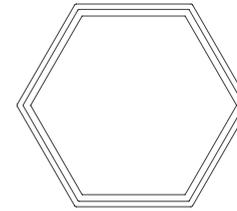



# Granpot

Una jardinera de forma clásica que ha crecido al extremo.

*A classic flower pot that has grown to the extreme.*

Una jardinera de forma clàssica que ha crescut a l'extrem.

*Une jardinière classique poussée à l'extrême.*

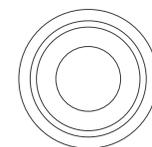
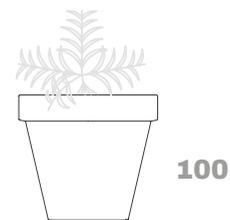

Ø 110 cm  
390 L





# Malva

Jardineras minimalistas que destacarán en cualquier espacio por su simplicidad estructural.

*Minimalist planters will stand out in any space for their structural simplicity.*

Jardineras minimalistes que destacaran a qualsevol espai per la seva simplicitat estructural.

*Des jardinières minimalistes remarquables dans n'importe quel espace par leur simplicité structurelle.*



Carrer Santa Maria, Preixana.



**Malva CO45 | 39 L**



40



Ø 45 cm

**Malva CO50 | 59 L**



50



Ø 50 cm

**Malva CO60 | 105 L**



60



Ø 60 cm

**Malva CO80 | 195 L**



60

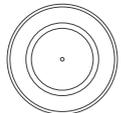

Ø 80 cm

**Malva CO4080 | 140 L**

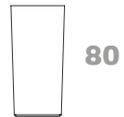

80



Ø 40 cm

**Malva CO50110 | 150 L**

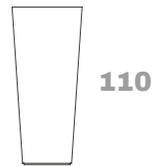

110



Ø 50 cm

**Malva PI6025 | 82 L**

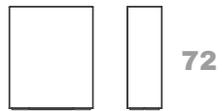

72

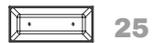

25

60 cm

**Malva PI8040 | 93 L**



40

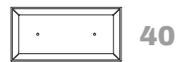

40

80 cm

**Malva PI9840 | 121 L**



40

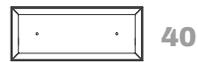

40

98 cm

**Malva PI40 | 48 L**  
**Malva PI4040 | 46 L**  
**Malva PI50 | 96 L**



52

40

64



40

40

50

40 | 40 | 50 cm

**Malva PI90 | 102 L**

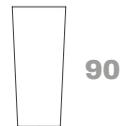

90



40

40 cm

**Malva PI10050 | 407 L**



70

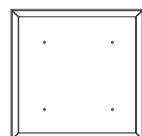

100

100 cm



Malva CO60, Malva PI90

# Uve



# Circular

**Circular small** | Ø90x52(h) cm | 228 L  
**Circular medium** | Ø90x63(h) cm | 271 L  
**Circular big** | Ø110x90(h) cm | 485 L

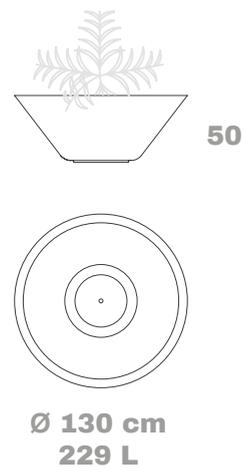
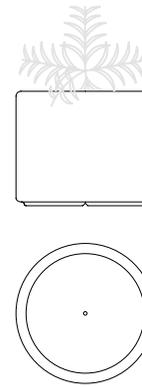

# Ese

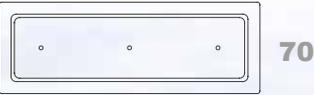

200 cm  
325 L



# Lis

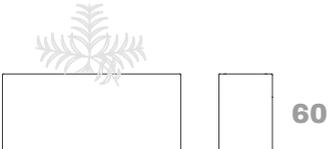

140 cm  
145 L

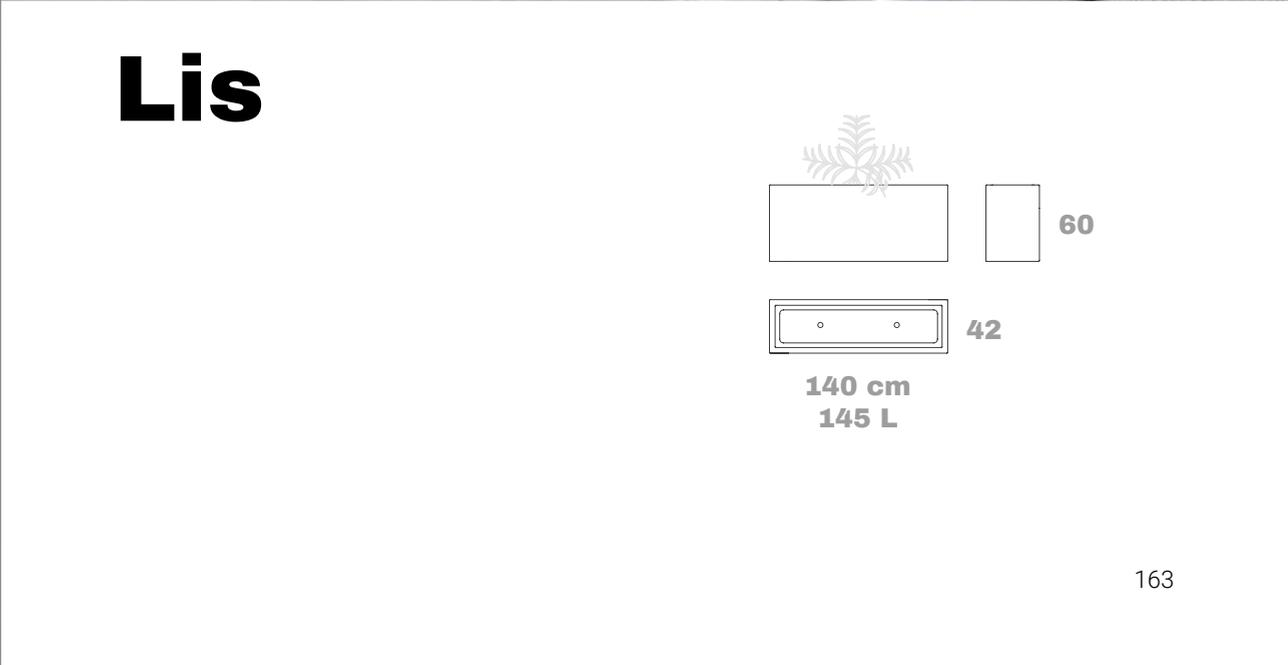



# Hat

by Benditas

Hat J 220 | 1.018 L

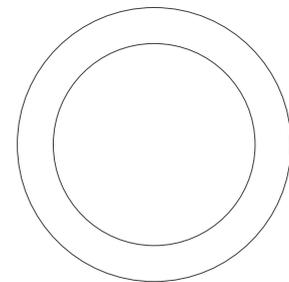
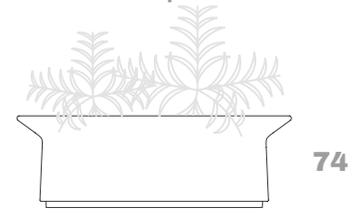

Ø 220 cm

Hat J 115 | 532 L

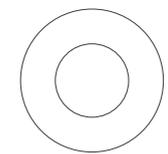
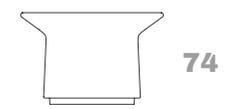

Ø 115 cm

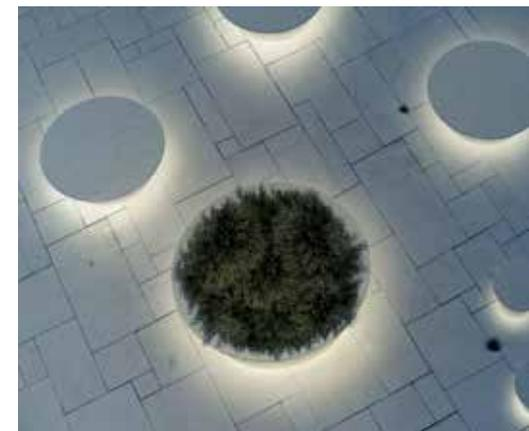

 Iluminación LED opcional  
Optional LED lighting

► Ver bancos Hat, p. 136  
See Hat benches, p. 136





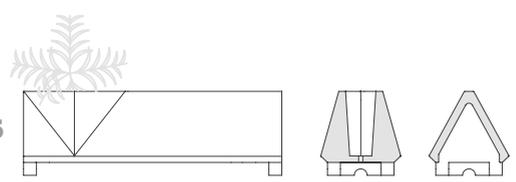

**Zaphir**  
 by Ton Riera

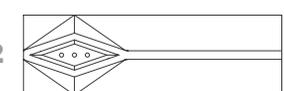
65 

62 
  
 200 cm

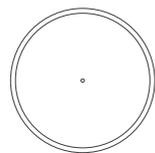

# Bol



Ø 119 cm  
262 L





# Espace

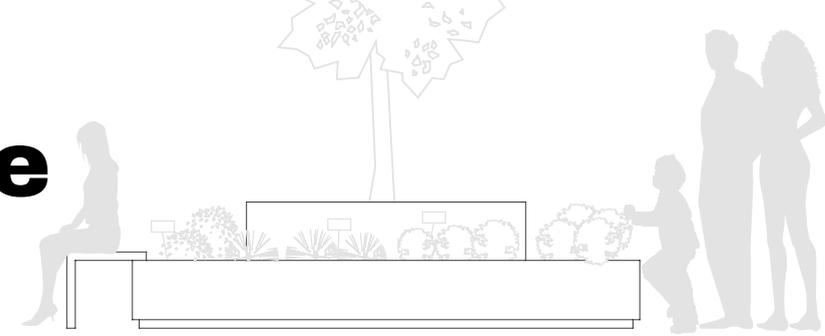

**Espace C | 1.690 L**

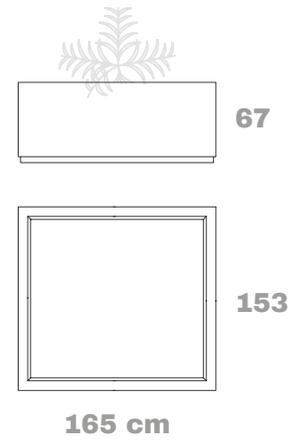

**Espace B**

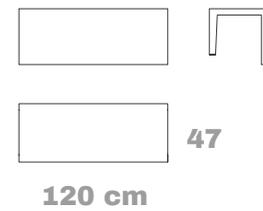

**Espace G | 3.360 L**

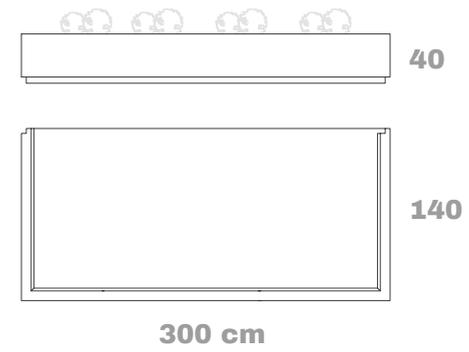

**Espace R | 1.440 L**

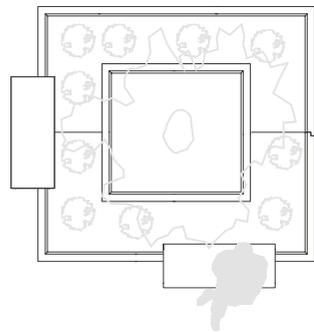
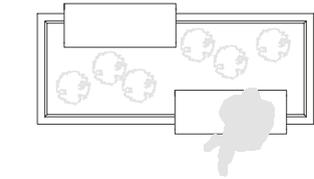
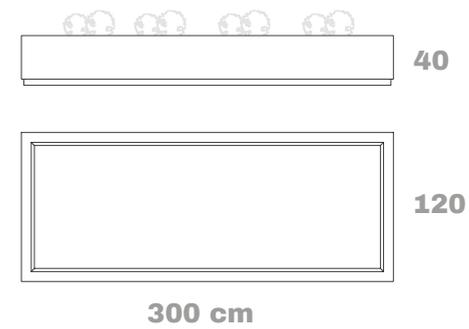

**Espace, huerto urbano | urban garden**



**recogida de residuos**  
**recollida de residus**  
***waste collection***  
***collecte de déchets***

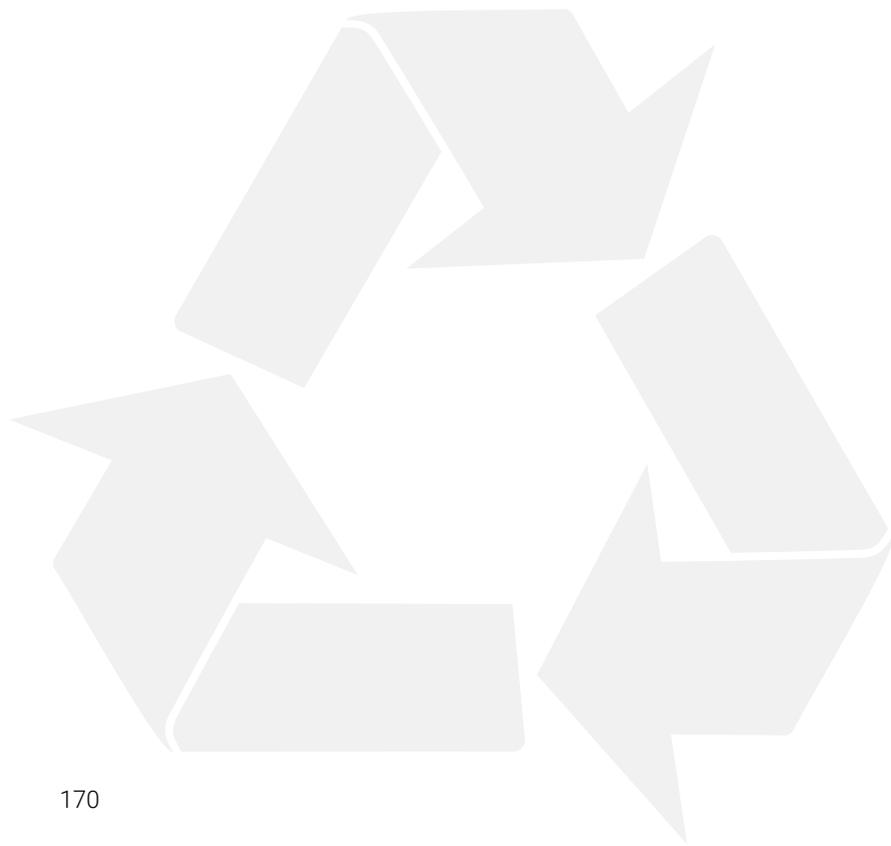



# Fory

by Estudi Ribaudí

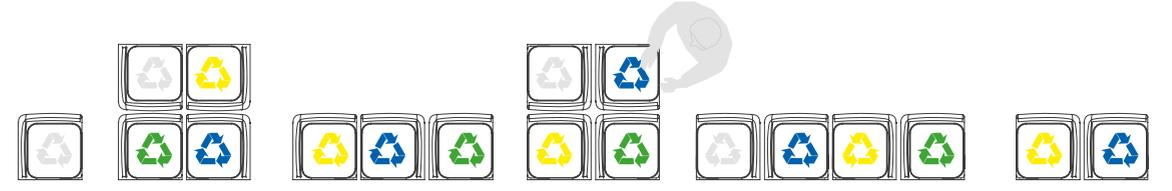
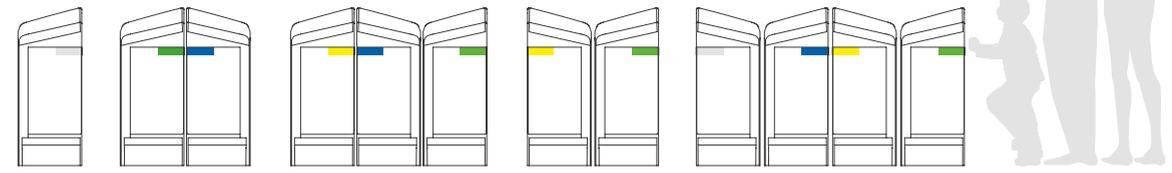
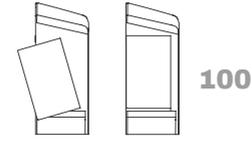

# James Bond

James | 120 L

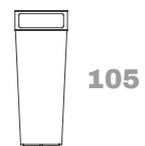

40 cm

Bond  
cenicero | ashtray

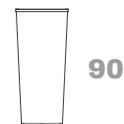

40 cm







**375**

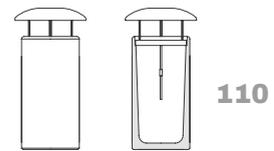

Ø 55 cm

**377**

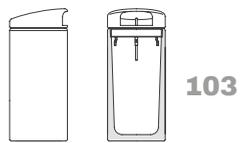

Ø 45 cm  
70 L



**Clip**

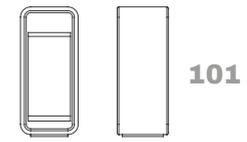

45 cm  
89 L





## 374N

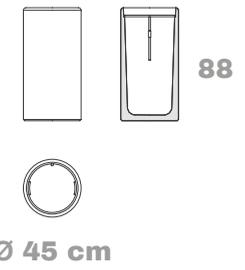

## 376

cenicero | ashtray

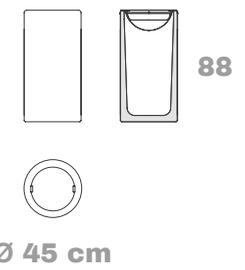

## 374N plus

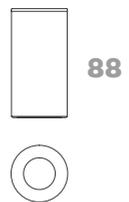

Ø 46 cm  
70 L

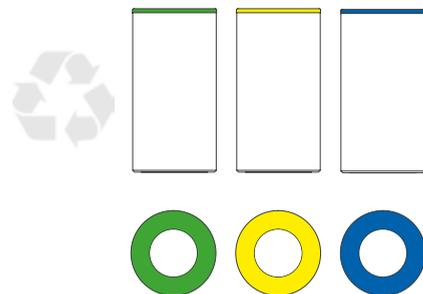

# Versatil

Versatil | 65 L

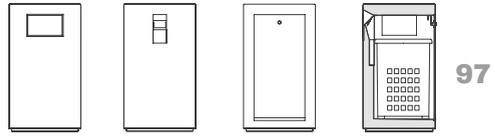

55  
55 cm



# Dynamic

## Dynamic P

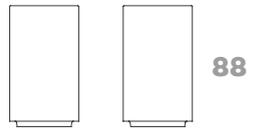

88



50

50 cm



Dynamic P

## Dynamic PG

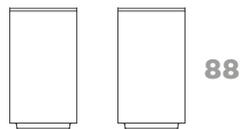

88



50

50 cm



Dynamic PG



Dynamic PB

## Dynamic PB

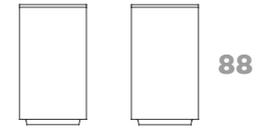

88



50

50 cm

## Dynamic P4E

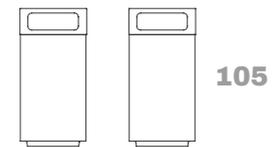

105



51

51 cm



Dynamic P4E

## Dynamic P2E

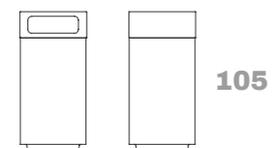

105



51

51 cm

● Ver bancos Dynamic, p. 130  
See Dynamic benches, p. 130

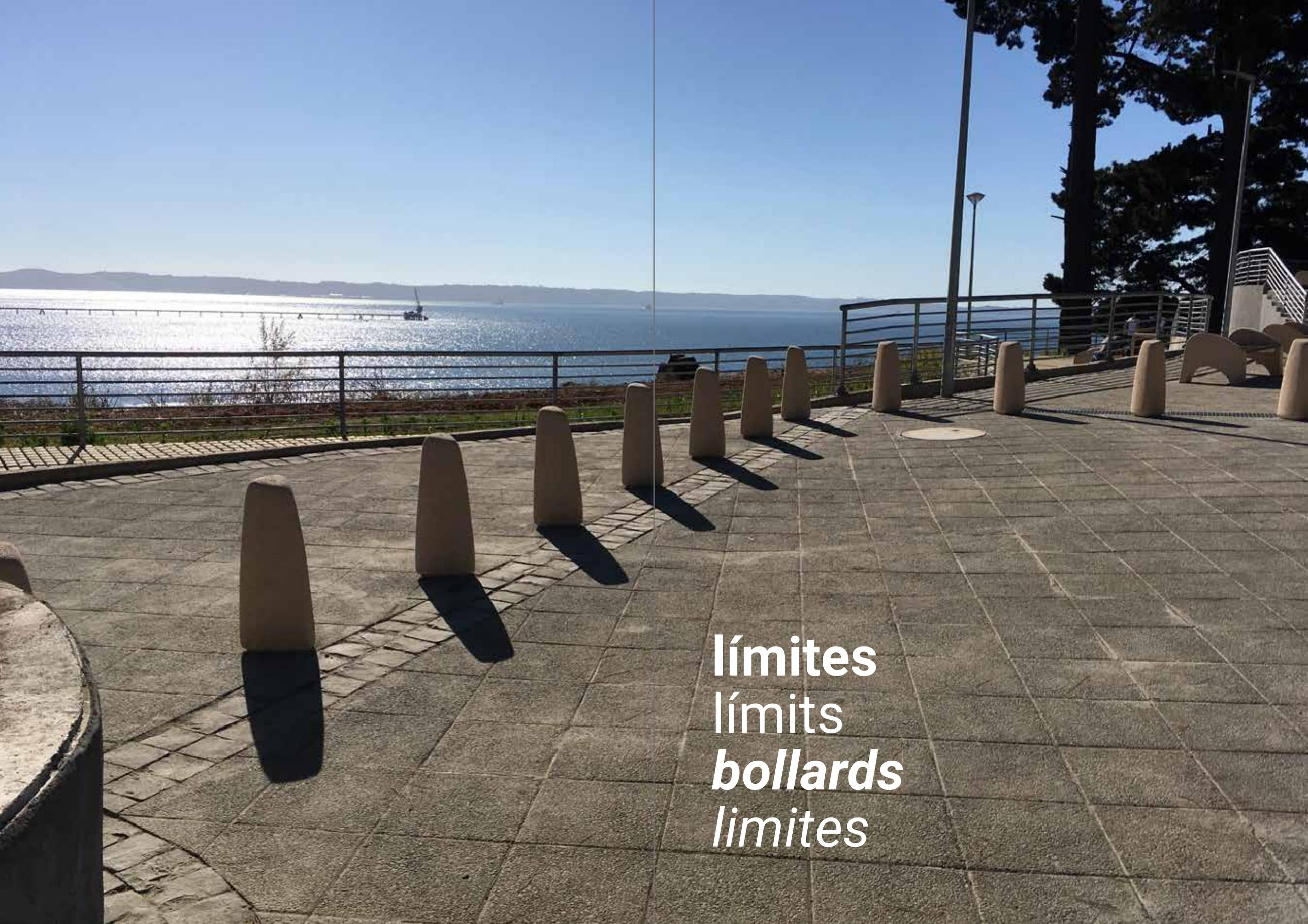

**límites**  
**límits**  
***bollards***  
***limites***

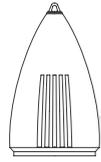
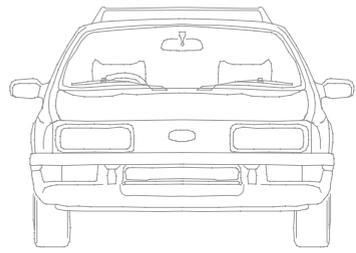

# Rodas

by Ton Riera

Rodas



110



Ø 68 cm

Rodas RF (reflectant)

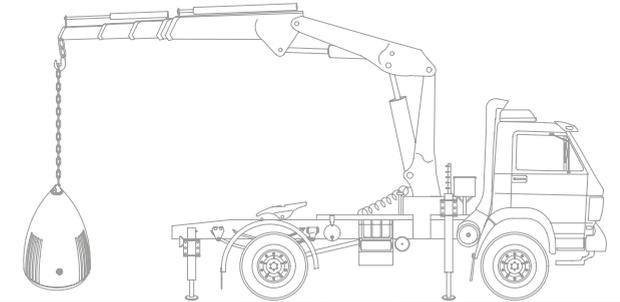

# Covert

by Estudi Ribaudí

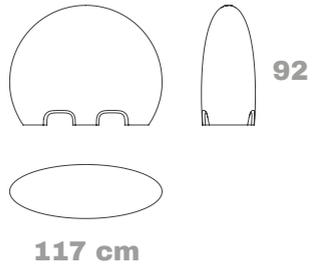
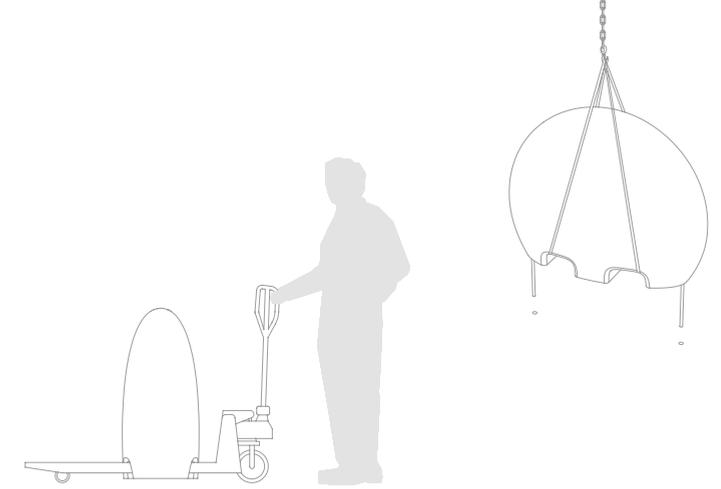

# Giro

by In-Tenta

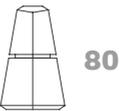
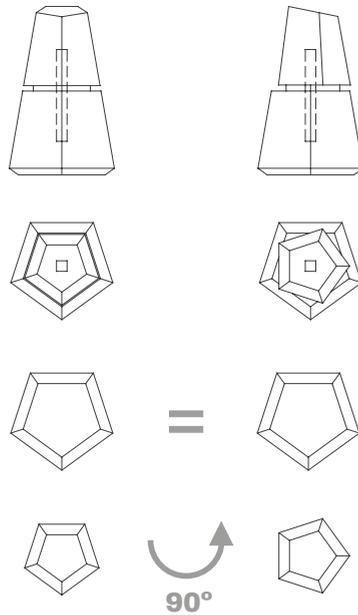
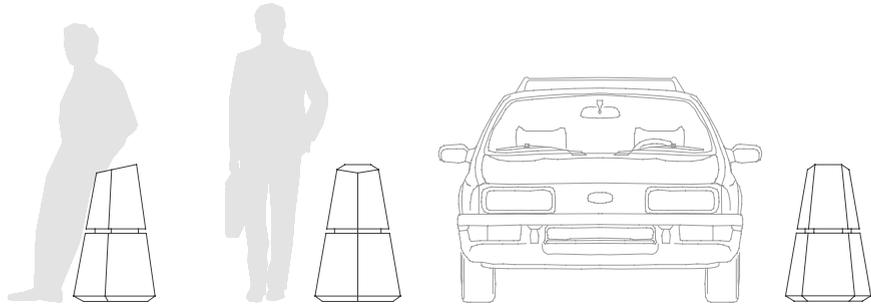
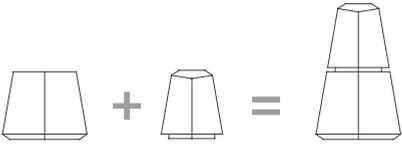

49 cm

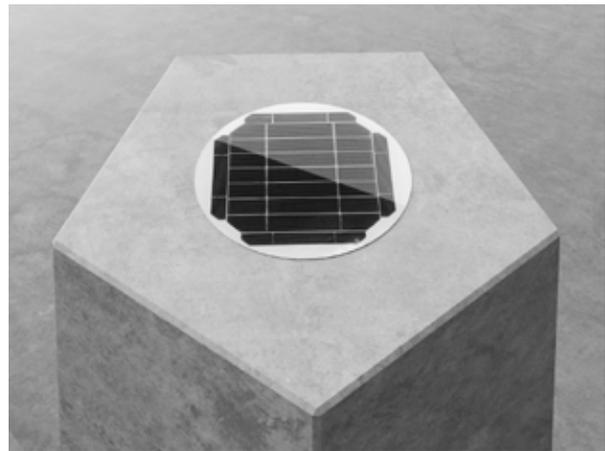

  =  Iluminación LED opcional  
Optional LED lighting





**Balisa JM** *by Jordi Miralles, Jordi Miró*

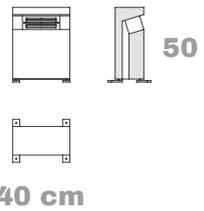

**Cilò** *by Ernest Perera*

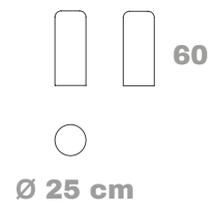

**Ursus** *by Xavier Bruçet*

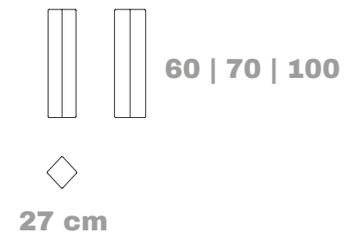

**Pausita** *by Oriol Guimerà*

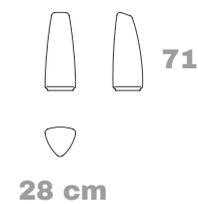

**Quad**

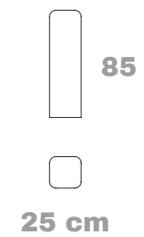

**Hiroki**

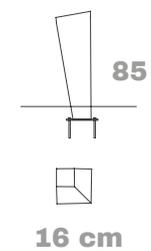



# 128 ... 138N

128 | 30x30x30(h) cm  
 129 | 35x35x35(h) cm  
 130 | 40x40x40(h) cm  
 131 | 45x45x45(h) cm

136N | Ø 45x26(h) cm  
 137N | Ø 45x38(h) cm  
 138N | Ø 45x47(h) cm

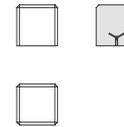

120 | Ø 30 cm  
 121 | Ø 35 cm  
 122 | Ø 40 cm  
 123 | Ø 45 cm  
 124 | Ø 55 cm

121B | Ø 35x18(h) cm  
 122B | Ø 40x20(h) cm  
 123B | Ø 45x23(h) cm  
 124B | Ø 55x28(h) cm

123C | Ø 45x45(h) cm

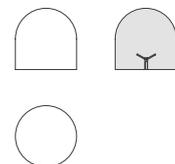
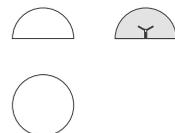
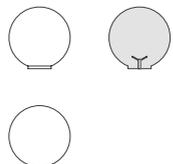

# 120 ... 124B

# 123E

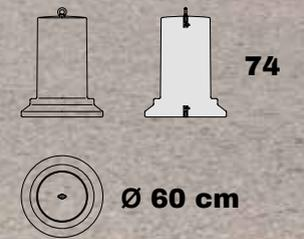
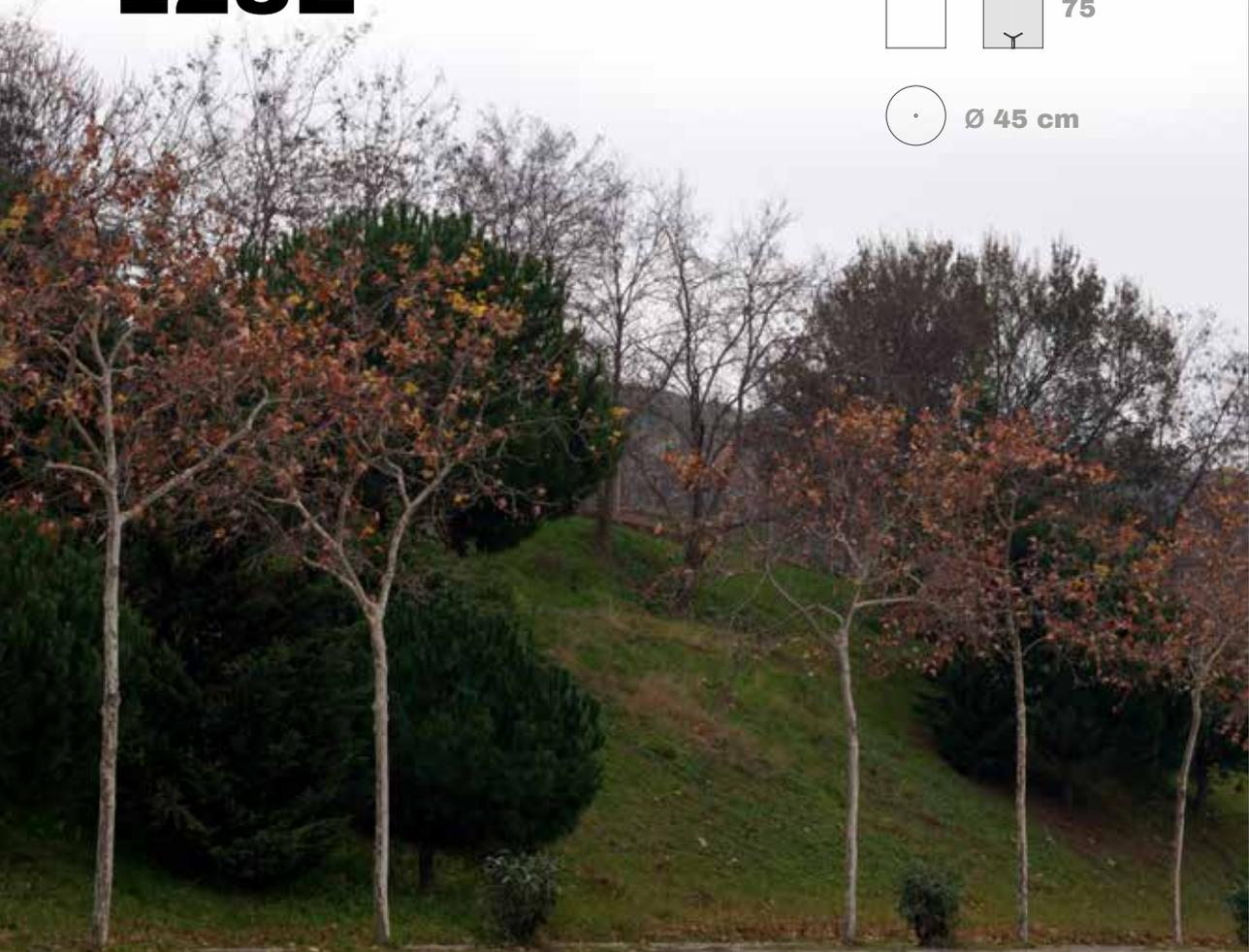
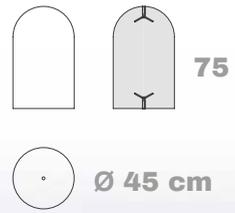

# 140



- 132 | 25x25x37(h) cm
- 133 | 28x28x60(h) cm
- 134 | 30x30x74(h) cm

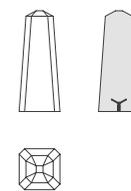

## 135

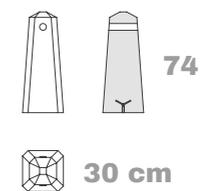

## 135/1

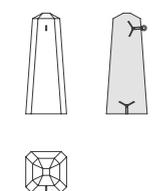

## 135/2

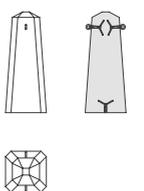

# 132 ... 135/2

**NY**  
by Benditas



## Tres

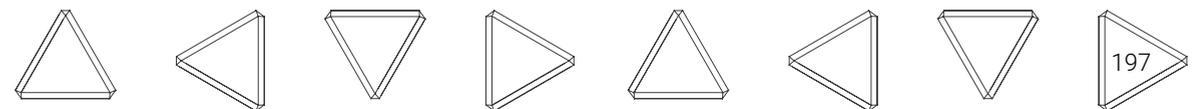
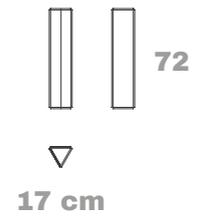



## Topy

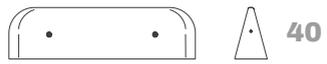

145 cm

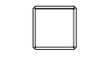

32 cm

## Teleno



## Esfera

Esfera 40 | Ø 40 cm

Esfera 50 | Ø 50 cm

Esfera 60 | Ø 60 cm

Esfera 80 | Ø 80 cm

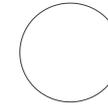
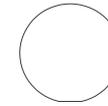

## Ufo

Ufo 40 | Ø 40 cm

Ufo 50 | Ø 50 cm

Ufo 60 | Ø 60 cm

Ufo 80 | Ø 80 cm

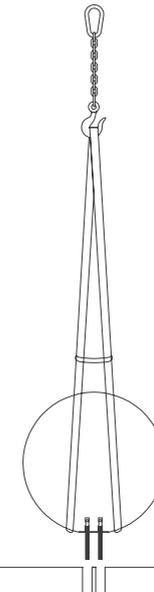
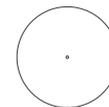



**picnic**  
**picnic**  
*picnic*  
*pique-nique*



► Ver Sun-Set, smart city line, p. 14  
 See Sun-Set, smart city line, p. 14

# Sun-Set

by In-Tenta

## Sun-Set picnic

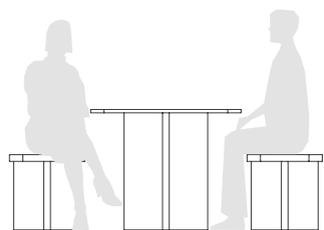
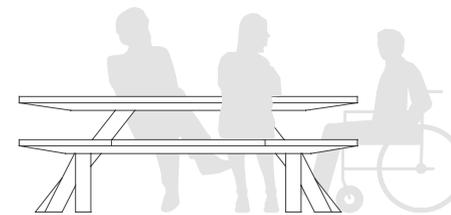
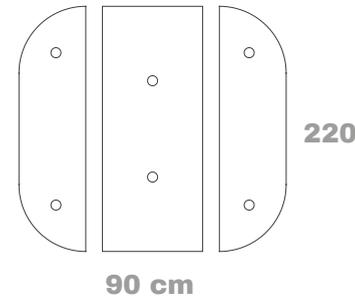
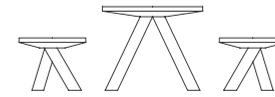

# Buseu

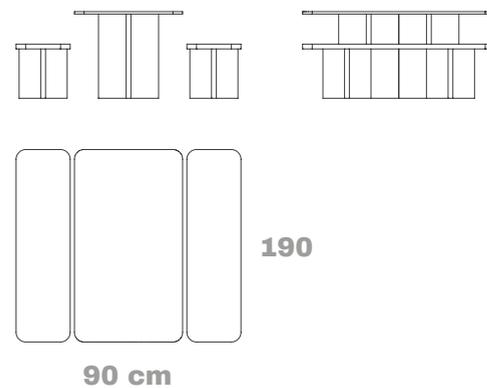

# Targa

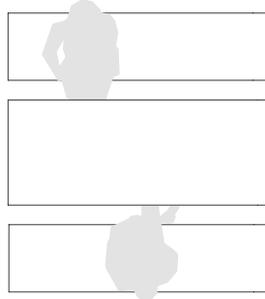

Targa T 77

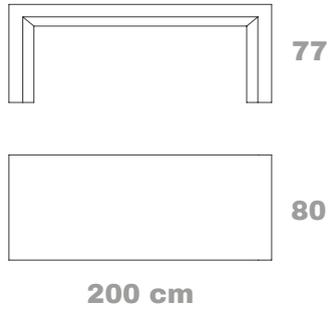

Targa B 50

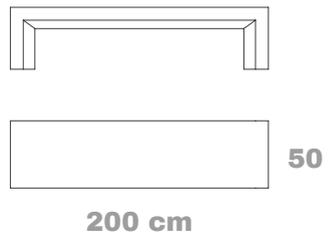

# Targa + Dynamic

Targa T 77

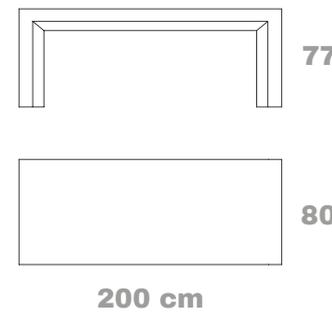

Dynamic I 200

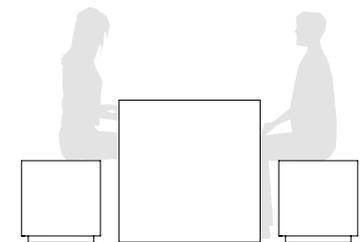
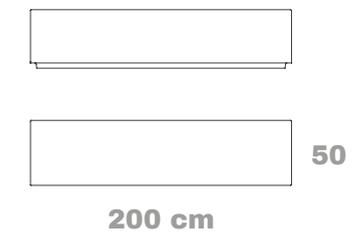





# Multi bench

by Hiroshi Tsunoda

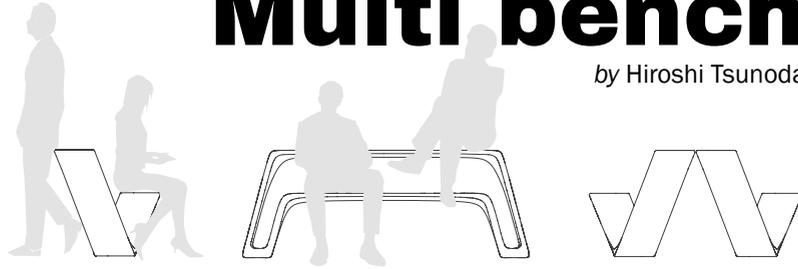

El término sentarse pierde formalidad en este banco. Un elemento diseñado sin estereotipos para utilizarse de diferentes modos.

El terme asseure's perd formalitat en aquest banc. Un element dissenyat sense estereotips per utilitzar-se de diferents maneres.

*The term sit down loses its formality with this bench. An element designed free of stereotypes, to be used in different ways.*

*Le verbe s'asseoir perd toute formalité sur ce banc. Un élément conçu sans stéréotypes, à utiliser de différentes manières.*

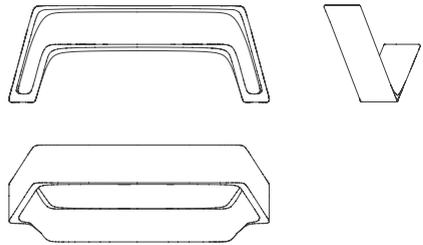

200 cm

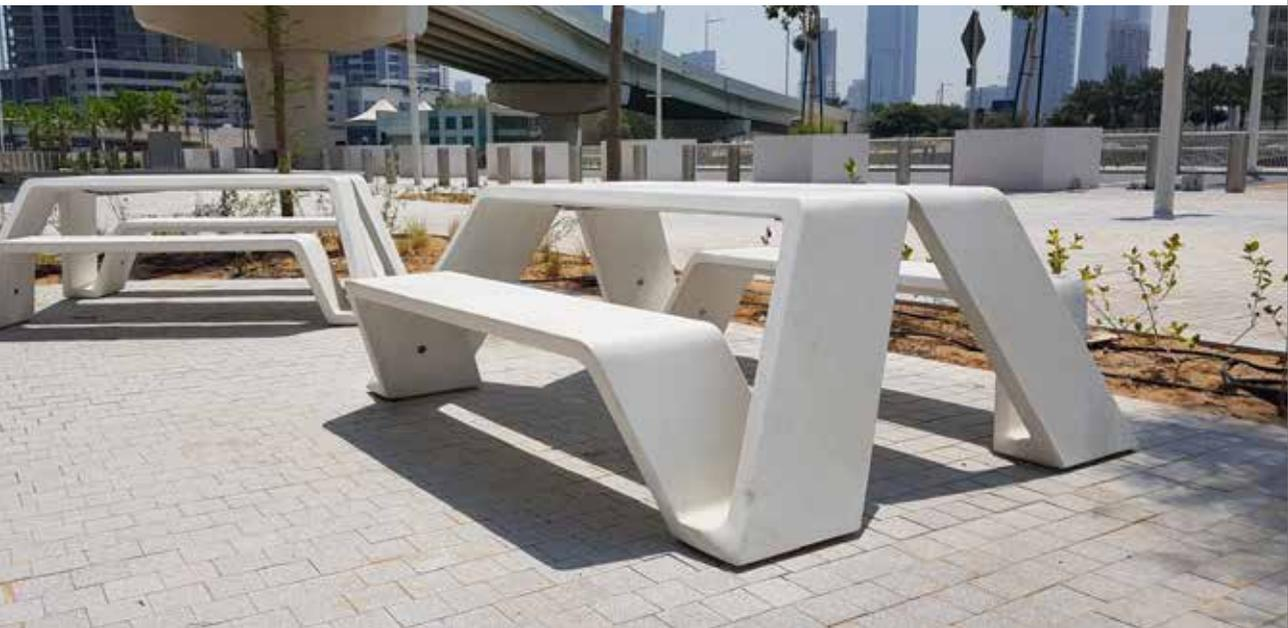

Triplex, Complex C



# Complex

by SUMA Arquitectes

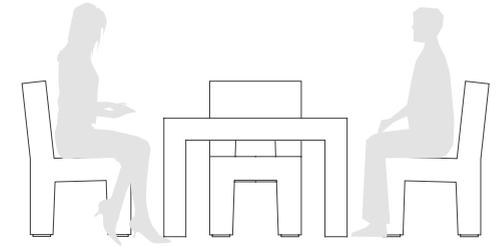

Complex A  
Complex B



52  
65

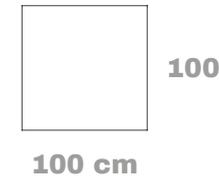

100

100 cm

Complex C



65

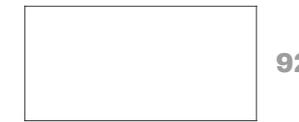

92

185 cm

Complex D



67



95

232 cm

Simplex <8

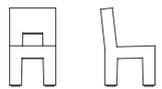

Simplex

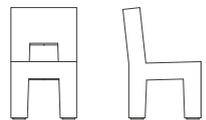

Triplex

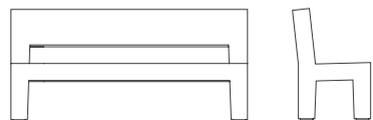

180 cm

Lex



232 cm

208

# Simplex

by SUMA Arquitectes



Lex, Complex D

# Loop

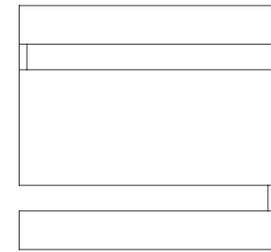
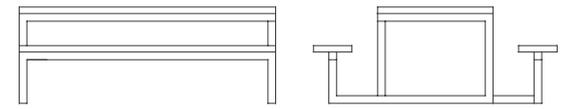

90

200 cm



**pavimentos**  
**paviments**  
***pavements***  
***revêtements***

# Ripple

by In-Tenta + Daniela Seminara

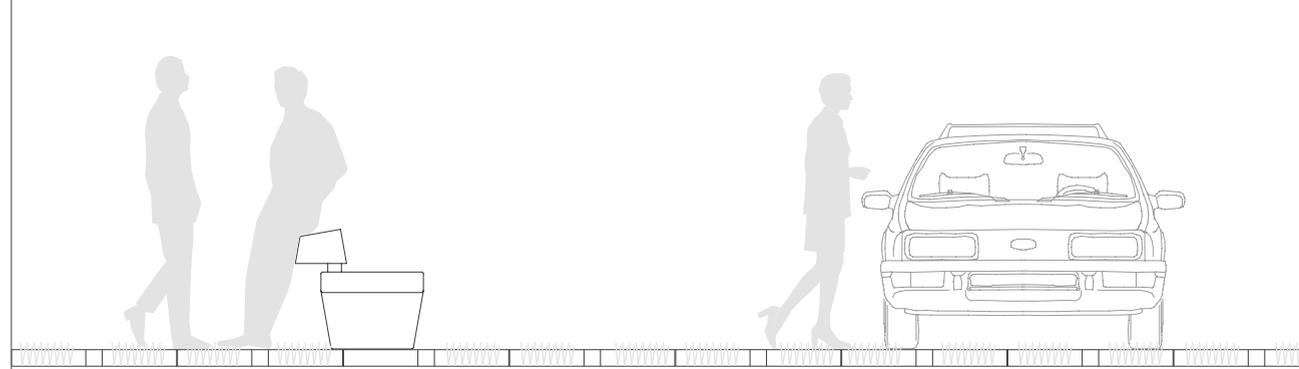
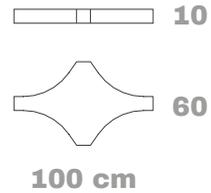

Pavimento verde que se inspira en las formas del desierto, cuyo diseño proporciona una sinuosa 'retícula' de hormigón y hierba para zonas de tráfico peatonal y vehículos ligeros.

Paviment verd que s'inspira en les formes del desert proporcionant una sinuosa 'retícula' de formigó i gespa per a zones de trànsit peatonal i vehicles lleugers.

*Green pavement inspired by the shapes of the desert. Its design creates a concrete and grass lattice for areas with pedestrian and light vehicle traffic.*

*Revêtement de sol vert inspiré par les formes du désert, dont la conception offre un 'treillage' sinuose de béton et d'herbe pour les zones de circulation des piétons et des véhicules légers.*

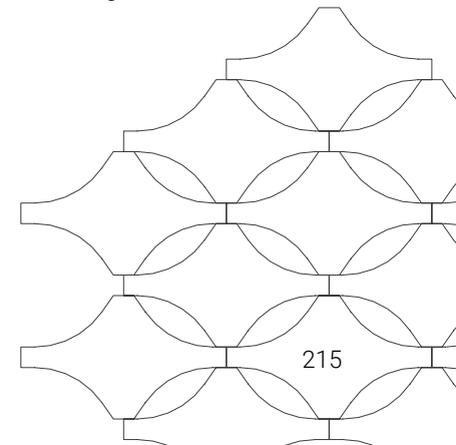



## Hoop



## Luna 60



## Toscana

by Arturo Frediani, arquitecto

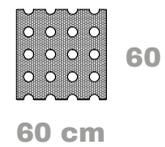

## Maira

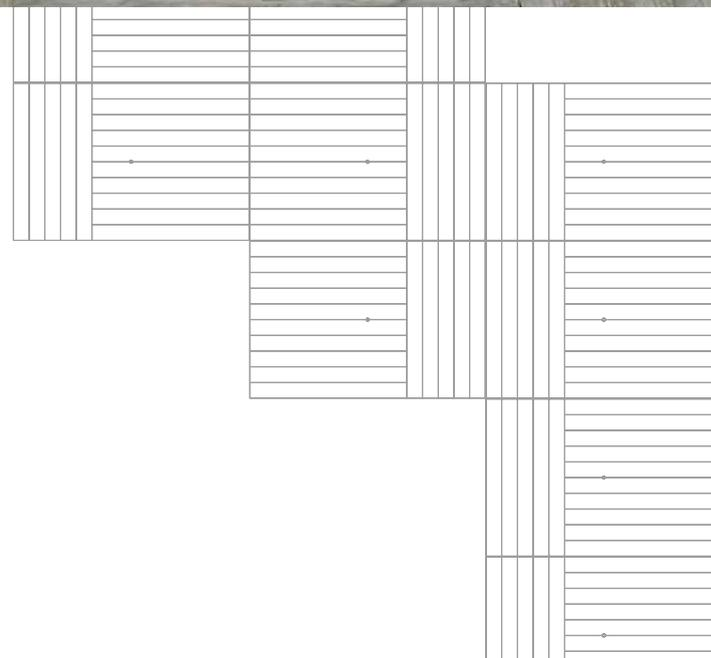
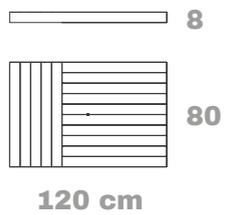



## Via láctea

by Ernest Perera

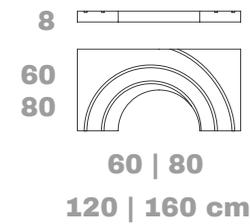

## Tv

by Ernest Perera

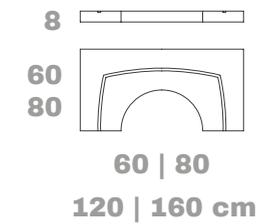

## Cap i cua

by Juan Carlos Bolaños

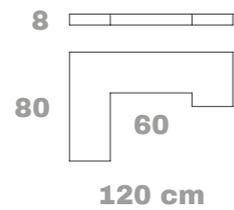

Mekano Q \_ SUMA Arquitectes



## Mekano Q

by SUMA Arquitectes

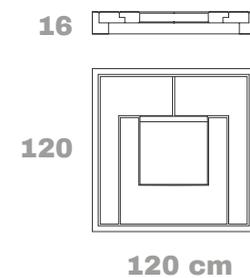

# Hospital Quirón Madrid

Pavimento Gran Formato | *Large-format Pavement*

PROMOTOR: Hospital Quirón  
ARQUITECTO: Albert Pineda, Pinearq, S.L.  
EMPLAZAMIENTO: Madrid





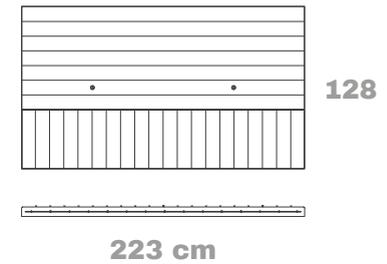
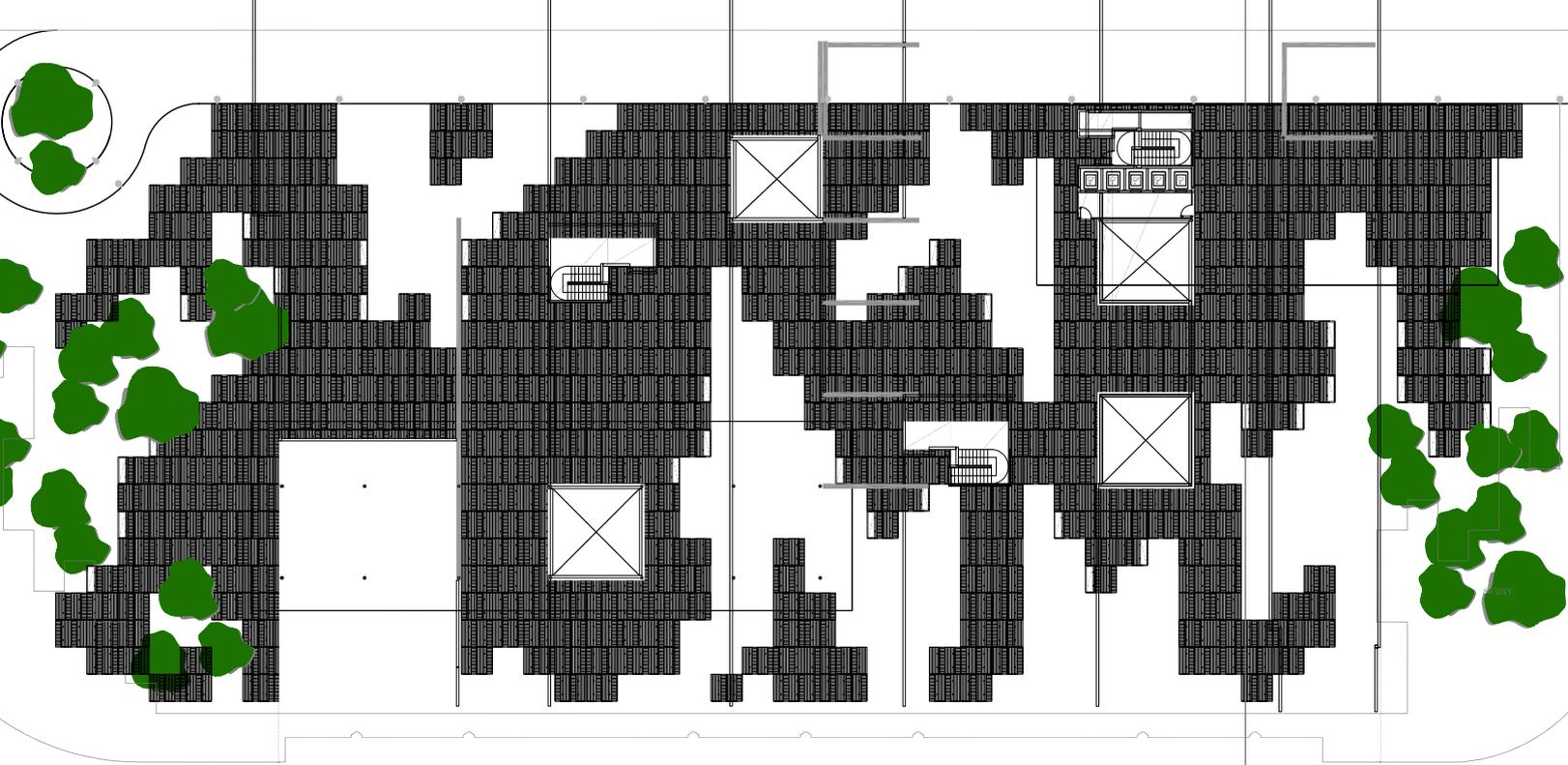

Hospital Quirón, Madrid.

# Jardines Mercè Vilaret

Pavimento Gran Formato | *Large-format Pavement*

PROMOTOR: ProEixample

ARQUITECTO: Ana Sánchez Patús

EMPLAZAMIENTO: Barcelona



Jardines Mercè Vilaret, Barcelona.

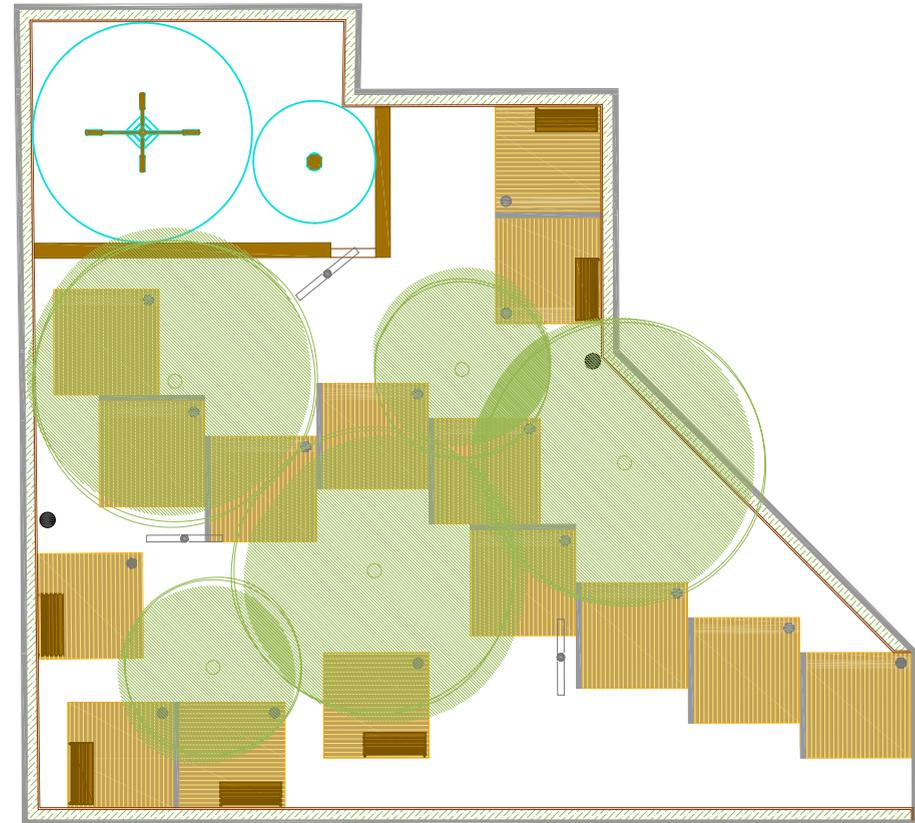
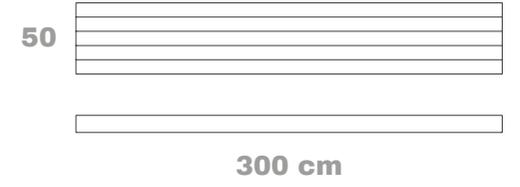

# BCN Biomedical Research Park

Pavimento Gran Formato | *Large-format Pavement*

PROMOTOR: Ajuntament de Barcelona

ARQUITECTO: Brullet i Associats, S.L.

EMPLAZAMIENTO: Barcelona

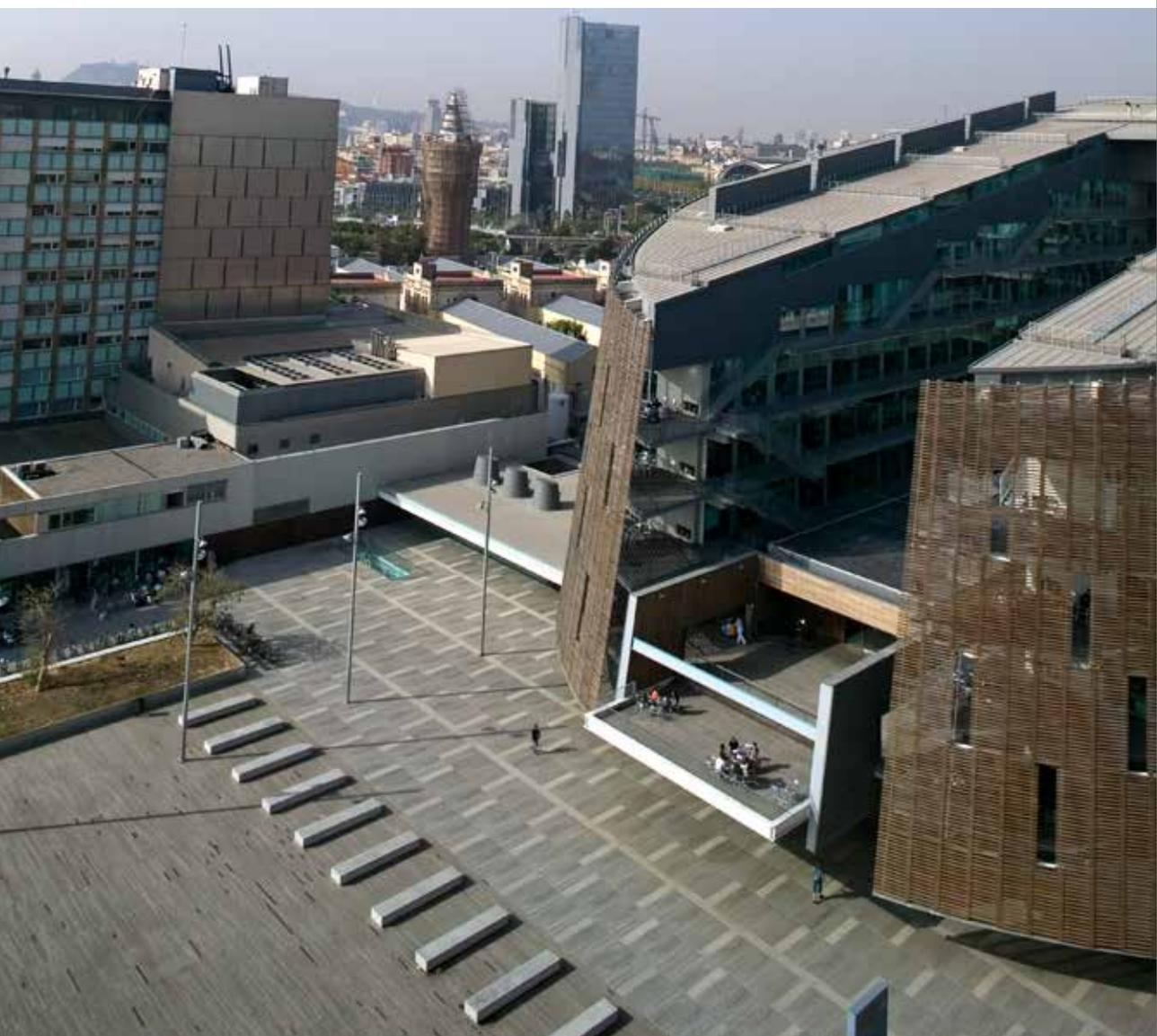

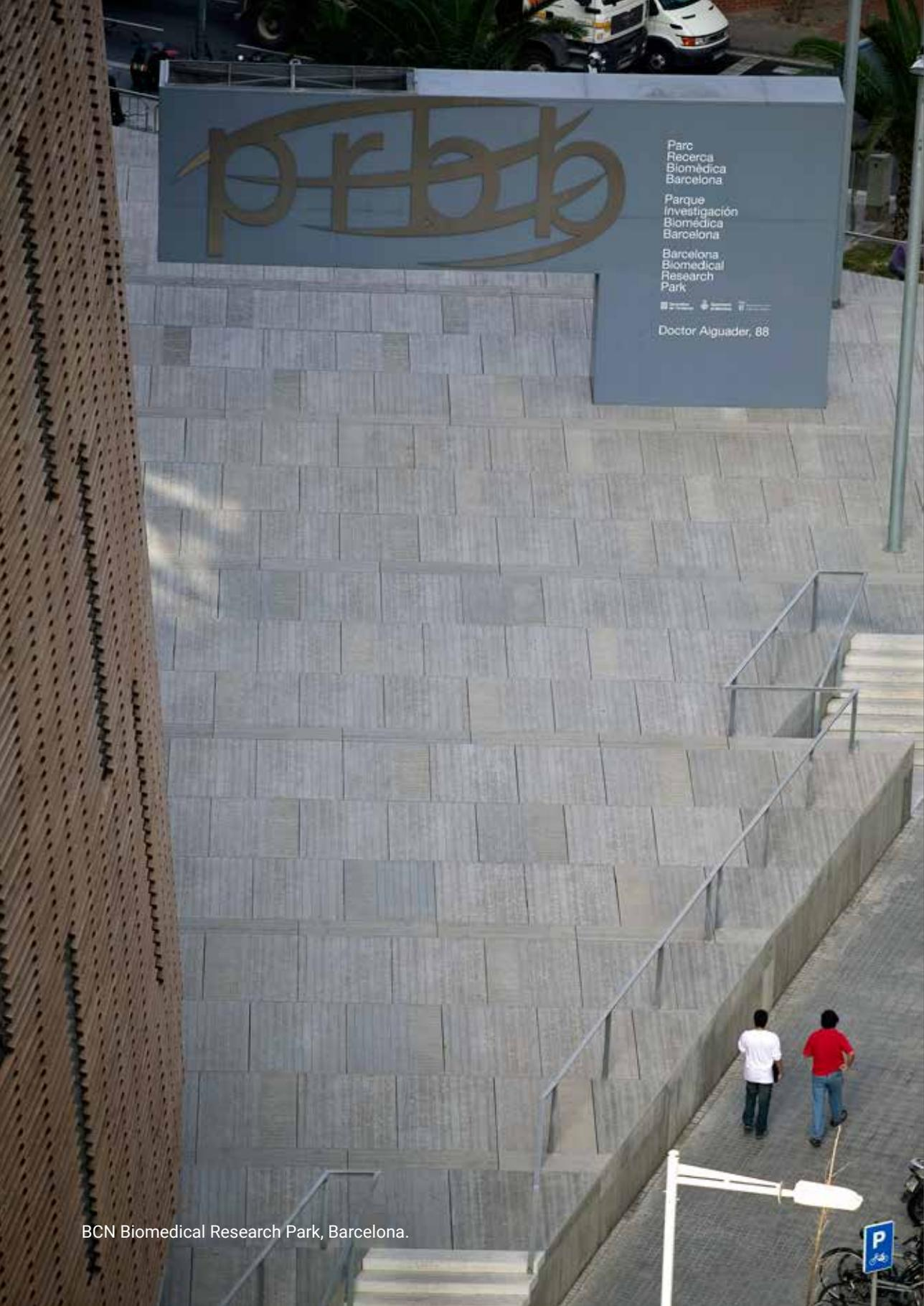

BCN Biomedical Research Park, Barcelona.

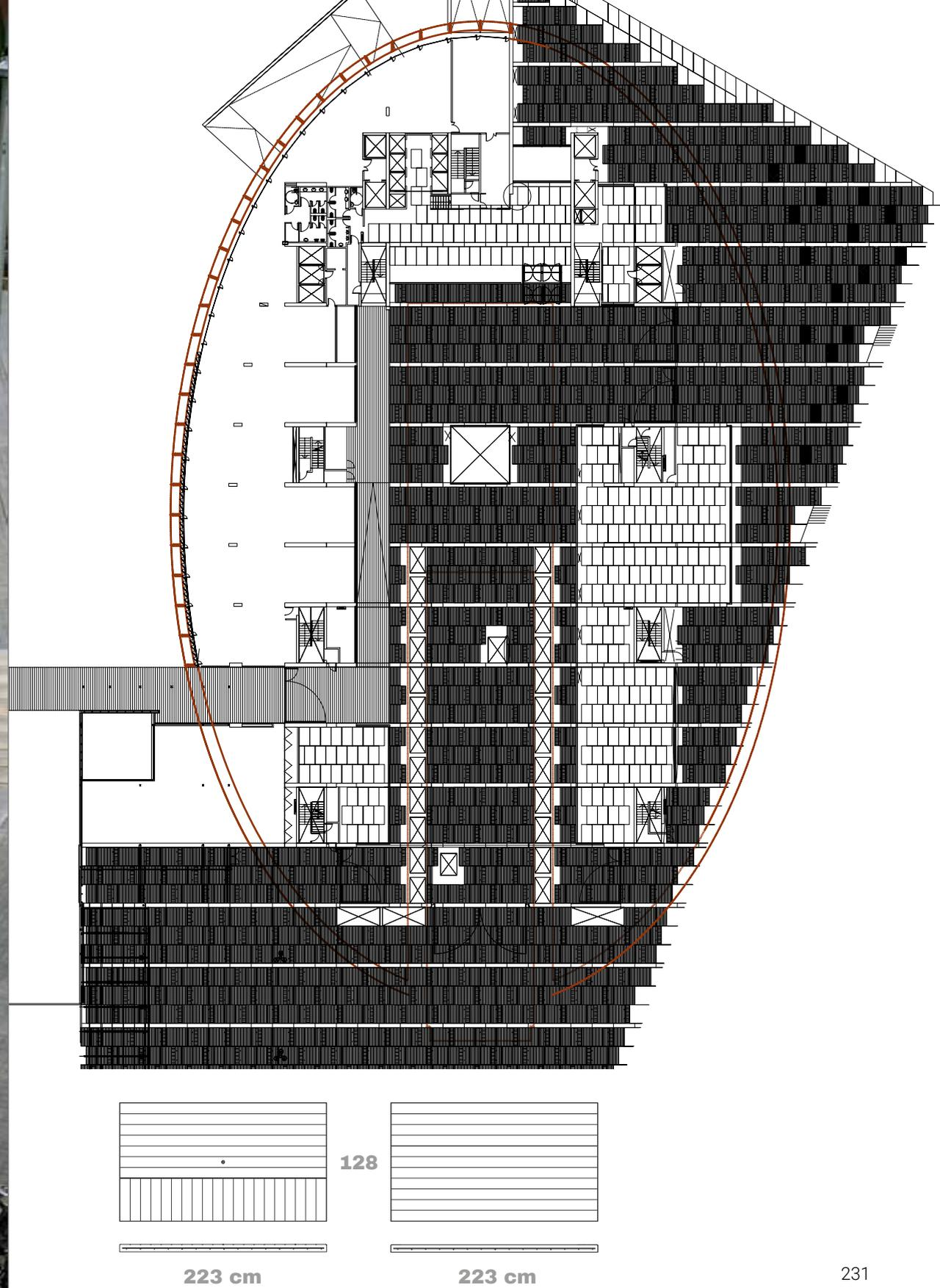

**miscelánea**  
**miscelània**  
***miscellaneous***  
***divers***



# Fontana

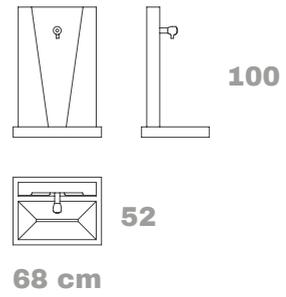

# Limitot

by Ton Riera

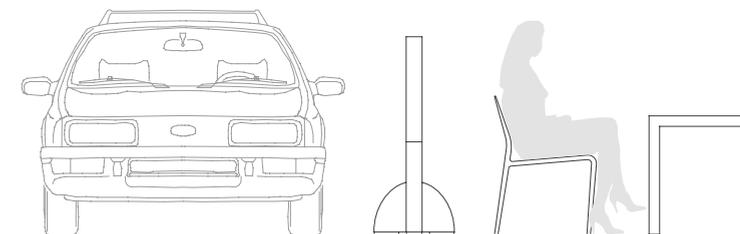
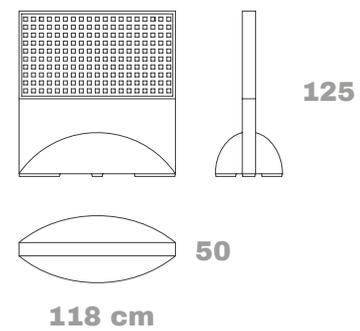

# Tube

by Roger Albero

Tube bike



78



76 cm



# Cyclo

by los diez

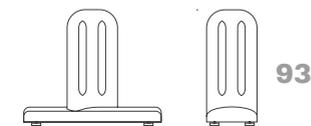

93



110 cm



# Pin

by CrousCalogero



34 cm



# Games



Targa B 50, Targa T 77 + Games

- Dimensión tableros de juego 40x40 cm.  
Disponibile para cualquier pieza de mobiliario MAGOURBAN con acabado Petra 1 y superficie horizontal.  
*Dimensions of game board 40x40cm.  
Available for any MAGOURBAN furniture pieces with an horizontal surface and Petra1 finish.*

**accessorios**  
**accessoris**  
**accessories**  
**accessoires**





## Antiskate

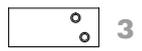

7 cm

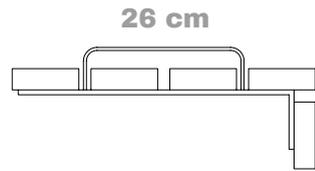

## Antisleep



## Plus



180 cm



48

27



## Plus 1



180 cm



40

51



## Plus 2

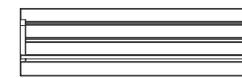

180 cm



40

51



## Plus 3

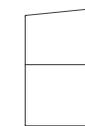

50 cm



86

55

# Plus 4

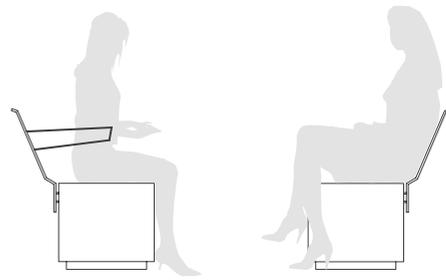

Plus 4 S



100 cm

Plus 4 D

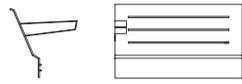

100 cm

Plus 4 E



100 cm

Plus 4 DE

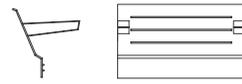

100 cm



Plus 5 D

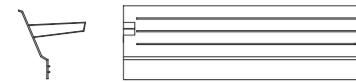

200 cm

Plus 5 E

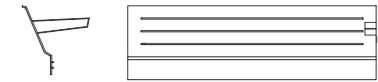

200 cm

Plus 5 S

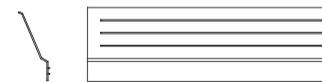

200 cm

Plus 5 DE

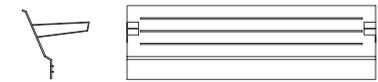

200 cm

Plus 5 C

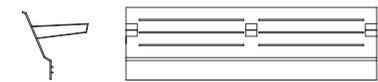

200 cm

# Plus 5



colores | colors



colores opcionales | optional colors

# Petra 1

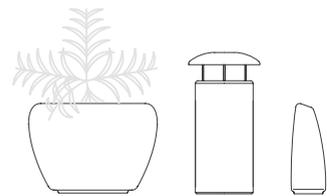

## acabados de superficie

Solo disponibles en:  
jardineras, recogida de residuos y límites

## surface finishes

Available:  
planters, waste collection and bollards



# SMC (UHPC)

acabado liso + antigraffiti  
smooth finish + antigraffiti

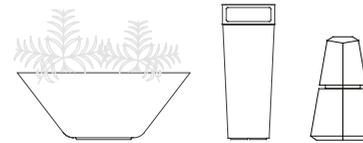

## acabados de superficie

Solo disponibles en:  
jardineras, recogida de residuos y límites

## surface finishes

Available:  
planters, waste collection and bollards

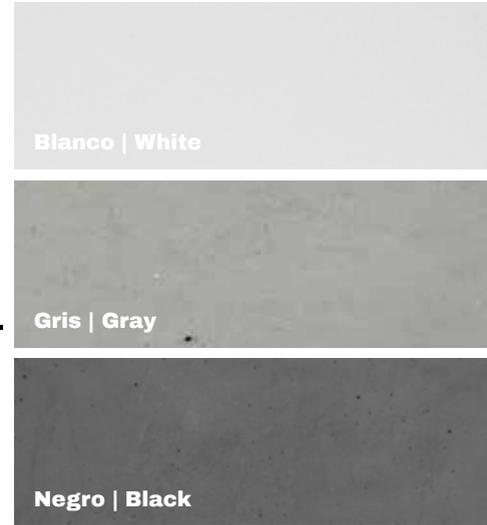
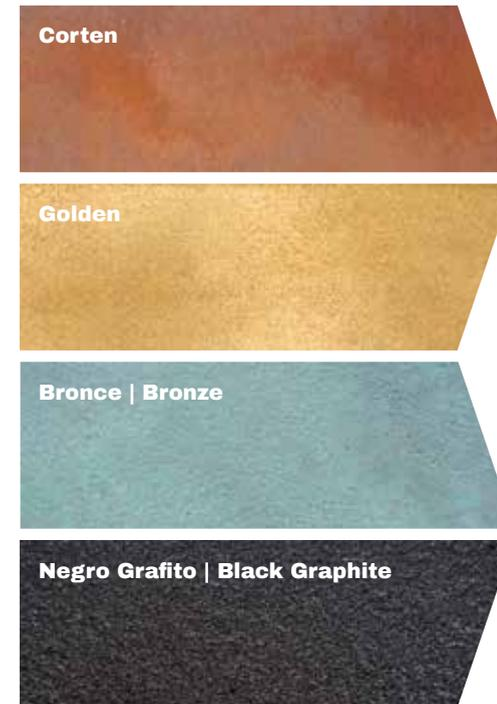

colores | colors

# DESIGNERS

Nuestra Colección de Autor es fruto de las ideas de arquitectos y diseñadores, y nuestros más de treinta años de experiencia en el sector.

La nostra Col·lecció d'Autor és fruit de les idees d'arquitectes i dissenyadors, i la nostra experiència de més de 30 anys en el sector.

*Our Signature Collection is result of the ideas of architects and designers, and our more than 30 years of experience in this field.*

*Notre Collection d'Auteur est le résultat des idées d'architectes et de designers et notre plus de 30 ans d'expérience dans le secteur.*

ALÒS IDEES  
ARTURO FREDIANI, ARQUITECTO  
BENDITAS  
BOW DESIGN  
CRISTINA NOGUER, JOAQUIM ROQUÉ, JOSEP MOTAS  
CROUSCALOGERO  
DANIELA SEMINARA  
EMBT / BENEDETTA TAGLIABUE  
ERNEST PERERA  
ESTUDI RIBAUDÍ  
EWALD WINKELBAUER  
FANTE&FABRÉ  
FOREIGN OFFICE ARCHITECTS  
GCA ARQUITECTES ASSOCIATS  
GUIDO MARSILLE  
HIROSHI TSUNODA  
IN-TENTA  
JAVIER GOROSTIDI, BERNARDO DEL PINO  
JESÚS ALFARO, ANA HURTADO  
JOAN CINCA  
JORDI MIRALLES  
JORDI MIRÓ  
JUAN CARLOS BOLAÑOS  
KUTARQ STUDIO + YHY DESIGN  
LA NOCHE DE LA IGUANA / KIKO SOLSONA  
LOS DÍEZ  
MIBA ARCHITECTS  
ORIOL GUIMERÀ  
ORIOL PARDO  
ROGER ALBERO  
STIMULO  
SUMA ARQUITECTES  
TON RIERA  
VENTURA VALCARCE  
XAVI FERRÚS  
XAVIER BRUCET





**from**

TÀRREGA | SPAIN

**to**

AUSTRIA · AUSTRALIA · BAHRAIN · BELGIUM  
 BRAZIL · BULGARIA · CHILE · CHINA · CHIPRE  
 CROATIA · DENMARK · ENGLAND · ESTONIA  
 FINLAND · FRANCE · GERMANY · GIBRALTAR  
 GREECE · HUNGARY · IRELAND · ITALY  
 LIECHTENSTEIN · LITHUANIA · MARTINIQUE  
 MOROCCO · NETHERLANDS · NORWAY  
 PANAMA · POLAND · PUERTO RICO · PORTUGAL  
 QATAR · ROMANIA · RUSSIA · SAUDI ARABIA  
 SINGAPUR · SLOVENIA · SWEDEN  
 SWITZERLAND · UNITED ARAB EMIRATES  
 UNITED STATES OF AMERICA · VENEZUELA





magourban

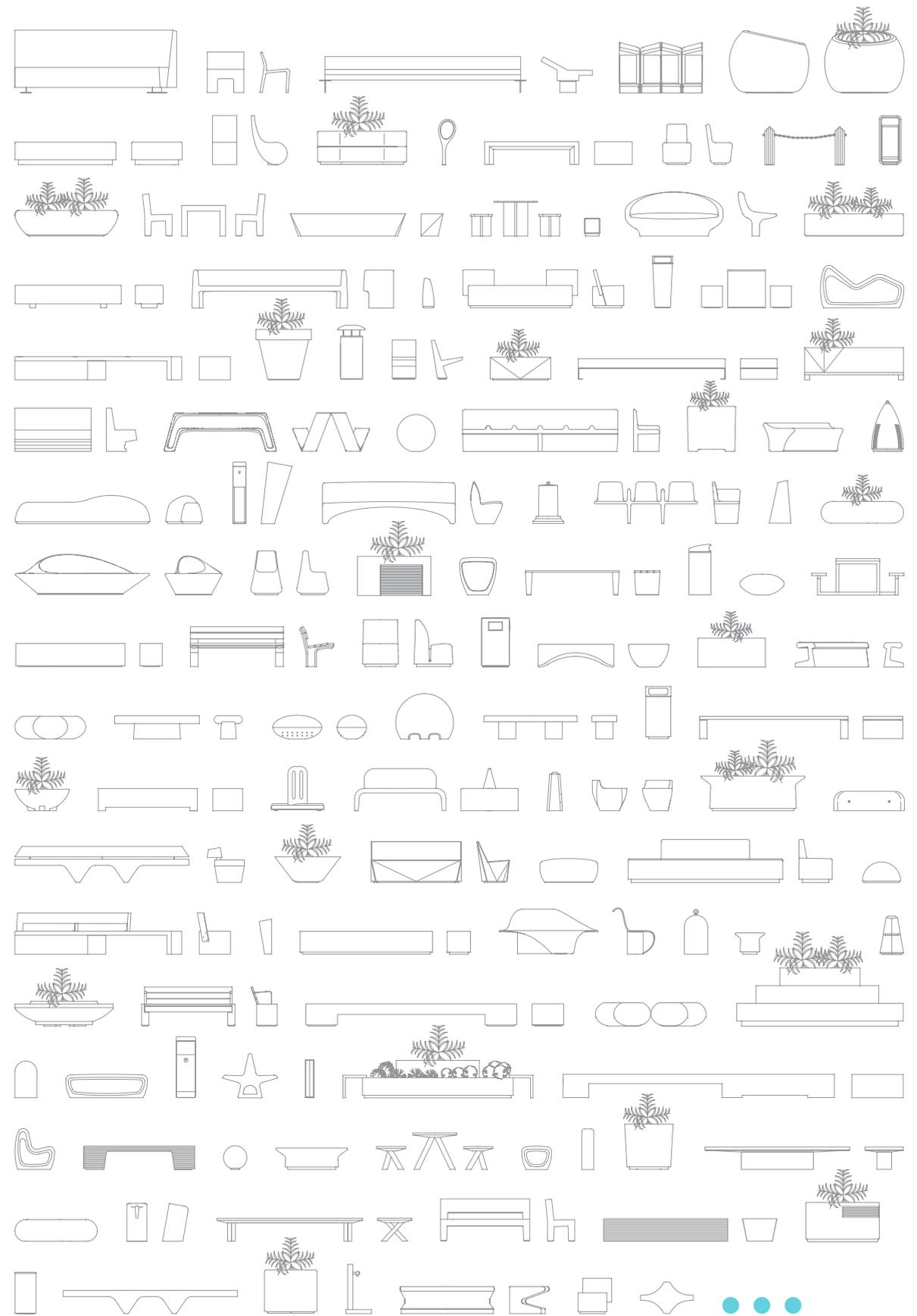





magourban

Avinguda de Cervera, 19  
25300 Tàrrega (Lleida)  
Tel. +34 973 158 703  
[comercial@magourban.com](mailto:comercial@magourban.com)

[magourban.com](http://magourban.com)